

ULTRAFAST COMPONENTS

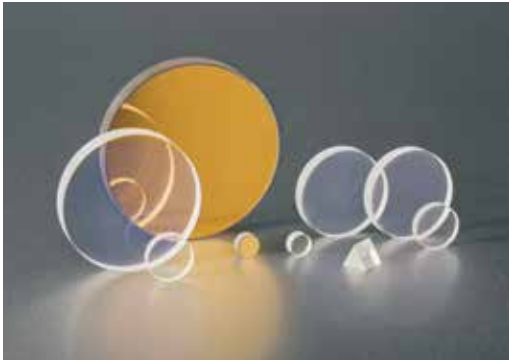

CVI Laser Optics offers both the PulseLine™ family of optical components and other existing product lines that are ideal for use with femtosecond lasers and associated applications. The PulseLine™ brand offers a broad range of high-performance laser optics designed to manage the effects of dispersion optimized at particular wavelengths while mitigating laser induced damage. These are ideal for use with tunable Ti:Sapphire, Ytterbium, and Erbium lasers and femtosecond light sources operating in either UV or visible regions. In addition, our other products lines outlined in this chapter have shown to be very capable of handling similar operating conditions, and have been listed for your convenience

SELECTION GUIDE	132
PULSELINE™ TI:SAPPHIRE MIRRORS	133
DIELECTRIC COATED MIRRORS	135
METAL COATED MIRRORS	138
PULSELINE™ FEMTOSECOND BEAMSPLITTERS	140
HIGH-ENERGY BROADBAND POLARIZING CUBE BEAMSPLITTERS	141

Don't see exactly what you are looking for?

CVI Laser Optics specializes in prototype to volume production manufacturing!

Give us a call and we will be honored to assist you with your custom needs.

NOTES:

SELECTION GUIDE

PRODUCT TYPE	OPERATING CONDITIONS	WAVE-LENGTHS	ANGLE OF INCI-DENCE	PERFORMANCE	PAGE
BROADBAND TI:SAPPHIRE MIRRORS: TLMW	0.35 J/cm ² , 50 psec, 50Hz at 800nm	720 – 900nm	0° or 45°	R > 99.0% for 720 – 900nm Broadband design with ultra low GDD	133
HIGH POWER TI:SAPPHIRE MIRRORS: TLMB	0.46 J/cm ² , 50 fsec, 50Hz at 800nm	740 – 860nm	0° or 45°	R > 99.0% for 740 – 860nm Broadband design with ultra low GDD	134
TUNABLE LASER LINE MIRRORS: TLM1	0.55 J/cm ² , 50 fsec, 50Hz at 800nm	From 190nm to 2100nm	0° or 45°	R > 99.5% at 355nm ≤ λ ≤ 2100nm; High Power design with low GDD	135
TUNABLE BROADBAND MIRRORS: TLM2	0.28 J/cm ² , 50 fsec, 50Hz at 800nm	450 – 2100nm	0° or 45°	R > 99.5% at 450nm ≤ λ ≤ 2100nm; Low Power design with ultralow GDD	136
ND:YAG 532NM LASER MIRRORS: Y2	20 J/cm ² , 20ns, 20Hz at 1064nm	532nm	0° or 45°	R > 99.9% at 0° incidence R > 99.8% at 45°, UNP	137
ND:YAG 1064NM LASER MIRRORS: Y1	25 J/cm ² , 20ns, 20Hz at 1064nm	1064nm	0° or 45°	R > 99.9% at 0° incidence R > 99.8% at 45°, UNP	137
PROTECTED SILVER METAL COATED MIRRORS: PS	~ 0.21 J/cm ² , 50 fsec, 50Hz at 800nm	400 – 20,000nm	0° – 45°	R _{avg} ≥ 95% (400nm to 20 μm)	138
PROTECTED GOLD METAL COATED MIRRORS: PG	~ 2 J/cm ² , 10ns, 10Hz at 1064 n	650 – 20,000nm	0° – 45°	R _{avg} ≥ 95.5% (650nm to 20 μm)	139
FEMTOSECOND BEAMSPLITTERS: FABS	~ 0.5 to 1 J/cm ² , 20ns, 20Hz at 1064nm	400nm, 800nm Custom	45°	Broadband all-dielectric R/T ratio 50:50	140
HIGH ENERGY BROADBAND POLARIZING CUBE BEAMSPLITTERS: PBSK	5 J/cm ² , 20ns, 20Hz; 1 MW/cm ² cw at 1064nm	248 – 308nm, 460 – 600nm, 700 – 900nm, 950 – 1230nm	0° - Incident and reflected beams separated by 117°	T _p > 92% at 800nm Extinction Ratio T _p /T _s > 103:1 Polarization bandwidth 140nm at 532nm	141

BROADBAND TI:SAPPHIRE MIRRORS: TLMW



Specifications

Product Code: **TLMW**

Substrate Material: N-BK7

Diameter: 25.4mm +0/-0.25mm

Thickness: 6.35mm ±0.25mm

Wedge: ≤5 arc minutes

Chamfer: 0.35mm leg width at 45° nominal

S1 Surface Figure: < $\lambda/10$ p-v at 633nm before coating; after coating on select substrates

S1 Surface Quality: 10-5 scratch-dig per MIL-PRF-13830b

S2 Surface Quality: Commercial polish

Clear Aperture: ≥85% of central diameter

Center Wavelength: 800nm

Angle of Incidence: 0° or 45° options

Reflectance:

0°: $R \geq 99.0\%$ from 720 - 900nm

45°: $R \geq 99.0\%$ from 720 - 900nm, UNP

Damage Threshold:

Pulsed: 0.35 J/cm², 50 fsec, 50Hz at 800nm

Bandwidth Tolerance: +0/-10% typical

Adhesion and Durability: Per MIL-C-48497a

The TLMW mirrors was specially designed to achieve a wider bandwidth (720 - 900nm) than our premier TLMB Ti:Sapphire mirror while maintaining high reflectivity, low dispersion and high damage threshold. These mirrors are designed for 800nm Ti:Sapphire laser applications with pulse lengths as low as 15 femtoseconds.

- ▶ Designed for Pulse Lengths > 15 fs
- ▶ Ultrahard coatings with LDT 1 J/cm², 180 fsec at 800nm
- ▶ High reflectivity: 720 - 900nm for 0° or 45° UNP
- ▶ Contact CVI Laser Optics for a range of custom options

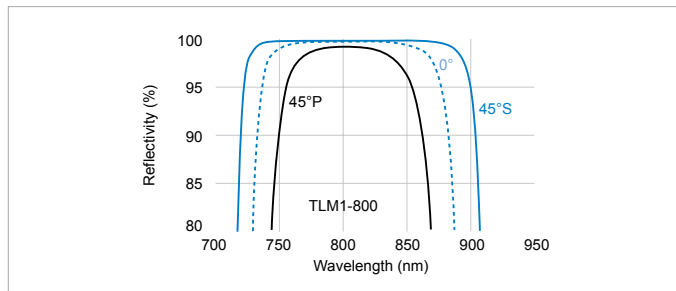

Reflectivity vs wavelength of TLMW-800 broadband laser mirror showing 0° and 45° angle of incidence designs

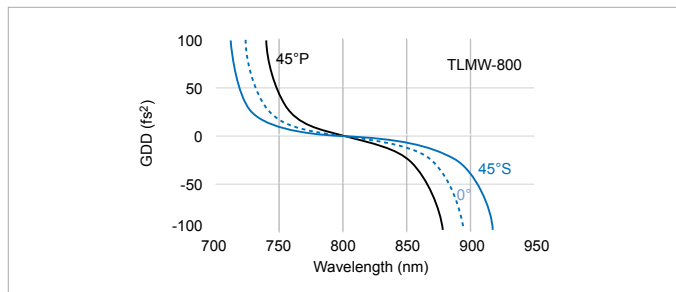

Group delay dispersion vs wavelength of TLMW narrowband laser mirror showing 0° and 45° angle of incidence designs

BROADBAND TI; SAPPHIRE MIRRORS:

Incidence Angle	PART NUMBER
0°	TLMW-800-0-1025
45°	TLMW-800-45-1025

HIGH POWER TI:SAPPHIRE MIRRORS: TLMB



Product Code: **TLMB**

Substrate Material: N-BK7

Diameter Tolerance: +0/-0.25mm

Thickness Tolerance: ±0.25mm

Wedge: ≤5 arc minutes

Chamfer:

Ø ≤ 50.8mm: 0.35mm leg width at 45° nominal
 Ø > 50.8mm: 0.85mm leg width at 45° nominal

S1 Surface Figure: $\lambda/10$ p-v at 633nm (after coating)

S1 Surface Quality: 10-5 scratch-dig per MIL-PRF-13830b (at 100W)

S2 Surface Quality: Commercial polish

Clear Aperture: ≥85% of central diameter

Angle of Incidence: 0° or 45° options

Center Wavelength: 800nm

Reflectance: R > 99.0% from 740 – 860nm for 0° or 45° UNP

Adhesion and Durability: Per MIL-C-48497a, Insoluble in lab solvents.

Damage Threshold:

Pulsed: 0.46 J/cm², 50 fsec, 50Hz at 800nm

These mirrors are available upon special request for all Ti:Sapphire laser-related center wavelengths.

- ▶ Designed for Pulse Lengths > 30 fs
- ▶ Broadband design with ultralow group velocity dispersion (GVD)
- ▶ High reflectivity: 740 – 860nm for 0° or 45° Unpolarized

BUILD YOUR PART NUMBER

STEP-1	STEP-2	STEP-3	STEP-4
PRODUCT CODE	WAVELENGTH	ANGLE OF INCIDENCE	SIZE CODE
TLMB	800	45	1025

EXAMPLE: TLMB-800-45-1025

CHOOSE FROM THE OPTIONS BELOW.

1. PRODUCT CODE

TLMB

2. WAVELENGTH (nm)

800

3. ANGLE OF INCIDENCE in Degrees

0	0 degrees (normal incidence)
45	45 degrees

4. SIZE CODE

SIZE CODE	DIAMETER (mm)	THICKNESS (mm)
2506M	25.0	6.0
1025	25.4	6.35
5010M*	50.0	10.0
2037	50.8	9.53
3050*	76.2	12.7
4050*	101.6	12.7

* Only available at 45° AOI

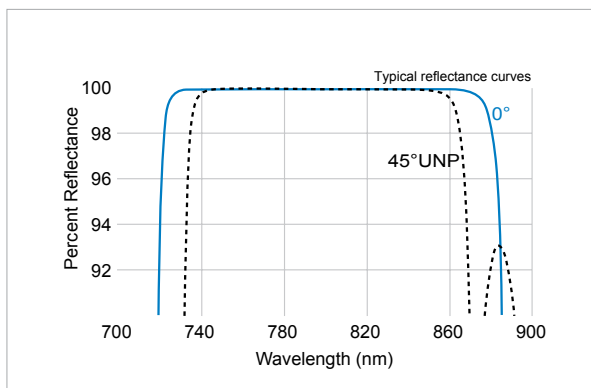

TLMB-800 Ti:Sapphire broadband mirror showing 0° and 45° angle of incidence designs

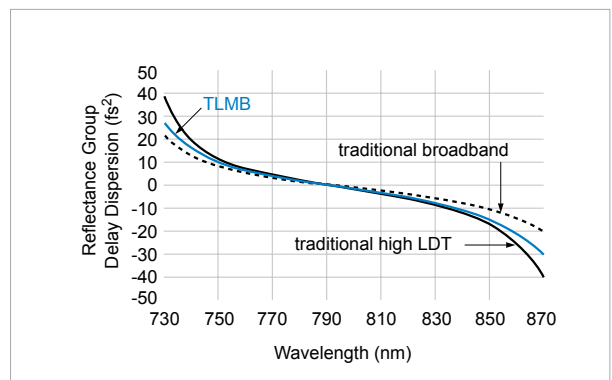

A comparison of group delay dispersion vs wavelength of traditional broadband, traditional high laser damage threshold, and the CVI Laser Optics TLMB ultrafast mirror

TUNABLE LASER LINE MIRRORS: TLM1



Specifications

Product Code: **TLM1**

Substrate Material:

$\lambda < 450\text{nm}$: Standard Grade Corning 7980 1-D (Fused Silica)

$\lambda > 450\text{nm}$: N-BK7

Diameter Tolerance: $\pm 0.025\text{mm}$

Thickness Tolerance: $\pm 0.25\text{mm}$

Wedge: ≤ 5 arc minutes

Chamfer:

$\emptyset \leq 50.8\text{mm}$: 0.35mm leg width at 45° nominal
 $\emptyset > 50.8\text{mm}$: 0.85mm leg width at 45° nominal

S1 Surface Figure: $< \lambda/10$ p-v at 633nm before coating; after coating on select substrates

S1 Surface Quality: 10-5 scratch-dig per MIL-PRF-13830b (at 100W)

S2 Surface Quality: Commercial polish

Concentricity: $\leq 0.05\text{mm}$ (spherical substrates only)

Radius Tolerance: $\pm 0.5\%$ (spherical substrates only)

Clear Aperture: $\geq 85\%$ of central diameter

Angle of Incidence: 0° or 45° options

Adhesion and Durability: Per MIL-C-48497a

Reflectance:

$R \geq 99.0\%$ at 0°

$R \geq 98.5\%$ at 45°, P-Pol

$R \geq 99.0\%$ at 45°, UNP

$R \geq 99.5\%$ at 45°, S-Pol

Damage Threshold:

Pulsed:

20 J/cm², 20ns, 20Hz at 1064nm

0.55 J/cm², 50 fsec, 50Hz at 800nm

5.0 J/cm², 10ns, 20Hz at 532nm

3.0 J/cm², 7ns, 20Hz at 266nm

Continuous Wave: 10 MW/cm² at 1064nm

Center Wavelength Tolerance: $\pm 3\%$

TYPICAL BANDWIDTH FOR TLM1 MIRRORS

Center Wave-length (nm)	R>99% 0°	R>99% 45°S	R> 98% 45°P
200	10*	12*	—
400-405	50	64	31
780	85	109	61
800	88	110	62
1030	99	123	74
1550	124	154	94

* R > 97.0%

BUILD YOUR PART NUMBER

STEP-1	STEP-2	STEP-3	STEP-4	STEP-5
PRODUCT CODE	CENTER WAVELENGTH	ANGLE OF INCIDENCE	SIZE CODE	RADII OPTIONS
TLM1	800	0	1025	1.00CC

EXAMPLE: TLM1-800-0-1025-1.00CC

CHOOSE FROM THE OPTIONS BELOW.

1. PRODUCT CODE

TLM1

2. CENTER WAVELENGTH (nm)

200	400-405	780	800	1030	1550
-----	---------	-----	-----	------	------

3. ANGLE OF INCIDENCE in Degrees

0	0 degrees (normal incidence)
45	45 degrees

4. FLAT SIZE CODE

Flat Size Code	Diameter (mm)	Thickness (mm)	Standard Options
0525	12.7	6.35	Flat or Radius
0725	19.1	6.35	Flat Only
1025	25.4	6.35	Flat or Radius
2037	50.8	9.53	Flat Only
3050	76.2	12.7	Flat Only
4050	101.6	12.7	Flat Only

5. RADIUS OF CURVATURE (m)

SIZE CODE	Diameter (mm)	RADII OPTIONS (m), cc = concave		RADII OPTIONS (m), cx = convex
0525	12.7	0.10CC	0.75CC	
		0.25CC	1.00CC	
		0.50CC		
1025	25.4	0.10CC	1.50CC	0.30CX
		0.25CC	2.00CC	0.50CX
		0.50CC	3.00CC	1.00CX
		0.75CC	5.00CC	
		1.00CC	10.00CC	

For Nd:YAG/Nd:YLF wavelengths see page 11

For ArF and KrF wavelengths see page 9

Please see page T-28 for High Reflection Coating Traces.

TUNABLE BROADBAND MIRRORS: TLM2



Specifications

Product Code: **TLM2**

Substrate Material: N-BK7

Diameter Tolerance: +0/-0.25mm

Thickness Tolerance: ±0.25mm

Wedge: ≤ 5 arc minutes

Chamfer: 0.35mm leg width at 45° nominal

Concentricity: ≤ 0.05mm (spherical substrates only)

Radius Tolerance: ±0.5% (spherical substrates only)

S1 Surface Figure: $\lambda/10$ p-v at 633nm before coating; after coating on select substrates

S1 Surface Quality: 10-5 scratch-dig per MIL-PRF-13830b (at 100W)

S2 Surface Quality: Commercial polish

Adhesion and Durability: Per MIL-C-48497a

Clear Aperture: ≥ 85% of central diameter

Center Wavelength: 780nm, 800nm, or 1030nm

Reflectance: Please refer to the typical bandwidth tables

Angle of Incidence: 45° only

Damage Threshold:

Pulsed:

0.28 J/cm², 50 fsec, 50Hz at 800nm

0.50 J/cm², 20ns, 20Hz at 1064nm

Center Wavelength Tolerance: ±3%

Designed for Pulse Lengths: > 30 fs

TYPICAL BANDWIDTH FOR TLM2 MIRRORS

Center Wave-length (nm)	R > 99% 0°	R > 99.5% S	R > 99% 45° P
800	156	197	76
1030	180	230	80

The TLM2 mirrors are specially designed to achieve high reflectivity and low dispersion for cw oscillators and low-fluence pulses. These mirrors can be coated for any angle of incidence from 0° to 60° and any center wavelength between 450nm and 2100nm for OEM applications. For 45° tuning mirror applications involving very short pulses or very broad bandwidths. Using s - polarization minimizes pulse distortion and maximizes average reflectivity.

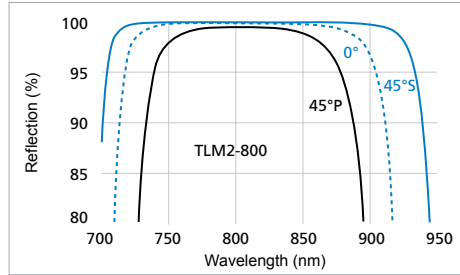

Reflectivity vs wavelength of TLM2-800 broadband laser mirror showing 0° and 45° angle of incidence designs

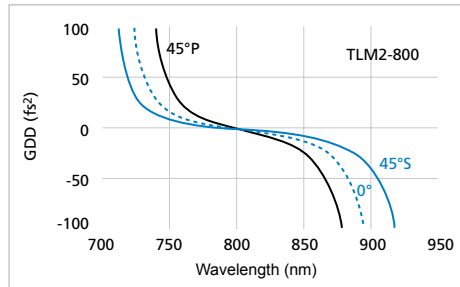

Group delay dispersion vs wavelength of TLM2-800 broadband laser mirror showing 0° and 45° angle of incidence designs

BUILD YOUR PART NUMBER

STEP-1	STEP-2	STEP-3	STEP-4
PRODUCT CODE	WAVELENGTH	ANGLE OF INCIDENCE	SIZE CODE
TLM2	800	45	1025

EXAMPLE: TLM2-800-45-1025

CHOOSE FROM THE OPTIONS BELOW.

1. PRODUCT CODE

TLM2

2. WAVELENGTH (nm)

800

1030

3. ANGLE OF INCIDENCE in Degrees

45

45 degrees

4. SIZE CODE

0525

DIAMETER (mm)

12.7

THICKNESS (mm)

6.35

1025

25.4

6.35

HIGH POWER Nd:YAG / Nd:YLF LASER MIRRORS: Y1, Y2



Specifications

Product Code: **Y1, Y2**

Substrate Material:

Standard Grade Corning 7980 1-D (Fused Silica)

Diameter Tolerance: +0/-0.25mm

Thickness Tolerance: ±0.25mm

Wedge: ≤5 arc minutes (flat substrates only)

Chamfer: 0.35mm leg width at 45° nominal

Concentricity: ±0.05mm (spherical substrates only)

Radius Tolerance: ±0.5% (spherical substrates only)

S1 Surface Figure: < λ/10 p-v at 633nm before coating; after coating on select substrates

S1 Surface Quality: 10-5 scratch-dig per MIL-PRF-13830b (at 100W)

S2 Surface Quality: Commercial polish

Clear Aperture: ≥85% of central diameter

Angle of Incidence: 0° or 45° options

Reflectance:

R ≥ 99.9% at 0°

R ≥ 99.6% at 45°, P-Pol

R ≥ 99.8% at 45°, UNP

R ≥ 99.9% at 45°, S-Pol

Adhesion and Durability: Per MIL-C-675c and MIL-C-48497a

Damage Threshold:

Pulsed:

25 J/cm², 20ns, 20Hz at 1064nm

20 J/cm², 20ns, 20Hz at 532nm

cw: 10 MW/cm² at 1064nm

USABLE BANDWIDTH (R _{AVG} ≥ 99.0%):	
Y1	1020 - 1100nm
Y2	510 - 560nm

BUILD YOUR PART NUMBER			
STEP-1	STEP-2	STEP-3	STEP-4
PRODUCT CODE	SIZE CODE	ANGLE OF INCIDENCE	RADII OPTIONS
Y1	1025	0	1.00CC

EXAMPLE: Y1-1025-0-1.00CC

CHOOSE FROM THE OPTIONS BELOW.

1. PRODUCT CODE	LASER TYPE	WAVELENGTH (nm)
Y1	Nd:YAG/Nd:YLF	1047-1064
Y2	Nd:YAG/Nd:YLF second harmonic	523-532

2. SIZE CODE	DIAMETER (mm)	THICKNESS (mm)
0525	12.7	6.35
1025	25.4	6.35
1537	38.1	9.53
2037	50.8	9.53
3050	76.2	12.7
4050	101.6	12.7

3. ANGLE OF INCIDENCE in Degrees	
0	0 degrees (normal incidence)
45	45 degrees

4. RADIUS OF CURVATURE (m)			
SIZE CODE	Diameter (mm)	RADII OPTIONS (m), cc = concave	RADII OPTIONS (m), cx = convex
0525	12.7	0.10CC	0.75CC
		0.25CC	1.00CC
		0.50CC	
1025	25.4	0.10CC	1.50CC
		0.25CC	2.00CC
		0.50CC	3.00CC
		0.75CC	5.00CC
		1.00CC	10.00CC

Please see page T-26 for High Reflection Coating Traces.

PROTECTED SILVER FLAT MIRRORS: PS



- ▶ Protected silver has higher reflectance than aluminum throughout the visible and near-infrared spectral region
- ▶ Minimal pulse distortion for ultrafast Ti:Sapphire lasers
- ▶ A proprietary overcoat provides increased durability
- ▶ CVI Laser Optics suggests using the drag and drop method with acetone for the cleaning of these mirrors.
- ▶ Contact an applications engineer for OEM capabilities

Specifications

Product Code: **PS**

Substrate Material: N-BK7

Dimensional Tolerances:

Square: +0/-0.25mm

Round: +0/-0.25mm

Thickness Tolerance: ±0.25mm

Parallelism: ≤5 arc minutes

Chamfer:

Ø ≤ 50.8mm: 0.35mm leg width at 45° nominal

Ø > 50.8mm: 0.85mm leg width at 45° nominal

S1 Surface Figure: < λ/10 p-v at 633nm on select substrates

S1 Surface Quality: 40-20 scratch-dig per MIL-PRF-13830b

S2 Surface Quality: Commercial polish

Clear Aperture:

Round: ≥85% of central diameter

Square: ≥80% of edge dimension

Coating: Protected silver

Average Reflectance: ≥95% at 400nm to 20µm

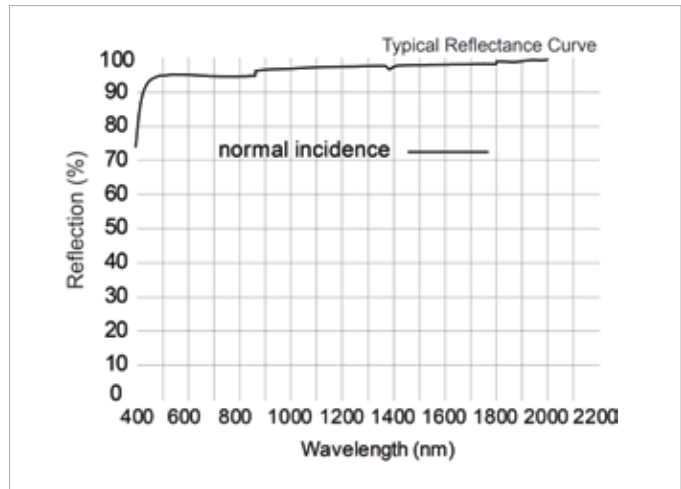

Protected silver coating at 0°

PROTECTED SILVER FLAT MIRRORS						
Shape	Ø (mm)	□ (mm)	t (mm)	Min. Clear Aperture (mm)	Surface Figure (S1)	PART NUMBER
Round	12.7	—	6.35	10.8	< λ/10	PS-PM-0525-C
Round	25.4	—	6.35	21.6	< λ/10	PS-PM-1025-C
Square	—	25.4	6.35	22.5x22.5	< λ/4	PS-SQM-1025-C
Round	50.8	—	9.53	43.2	< λ/10	PS-PM-2037-C
Square	—	50.8	9.53	45.0x45.0	< λ/4	PS-SQM-2037-C
Round	76.2	—	12.7	64.8	< λ/10	PS-PM-3050-C

PROTECTED GOLD FLAT MIRRORS: PG

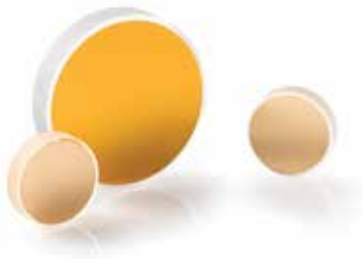

Specifications

Product Code: **PG**

Substrate Material: N-BK7

Dimensional Tolerances:

Square: +0/-0.25mm

Round: +0/-0.25mm

Thickness Tolerance: ±0.25mm

Parallelism: ≤5 arc minutes

Chamfer:

Ø ≤ 50.8mm: 0.35mm leg width at 45° nominal

Ø > 50.8mm: 0.85mm leg width at 45° nominal

S1 Surface Figure: < λ/10 p-v at 633nm on select substrates

S1 Surface Quality: 40-20 scratch-dig per MIL-PRF-13830b

S2 Surface Quality: Commercial polish

Clear Aperture:

Square: ≥80% of edge dimension

Round: ≥85% of central diameter

Coating: Protected gold

Average Reflectance: ≥ 95.5% at 650 – 1700nm,
≥98.0% at 2 – 20μm

- ▶ Protected gold combines the natural spectral performance of gold with the enhanced protection of a durable dielectric overcoat
- ▶ Protected gold provides 95.5% average reflectance from 650 to 1700nm, and over 98% average reflectance from 2 to 20 μm
- ▶ Contact an applications engineer for OEM capabilities and/or bare gold coatings

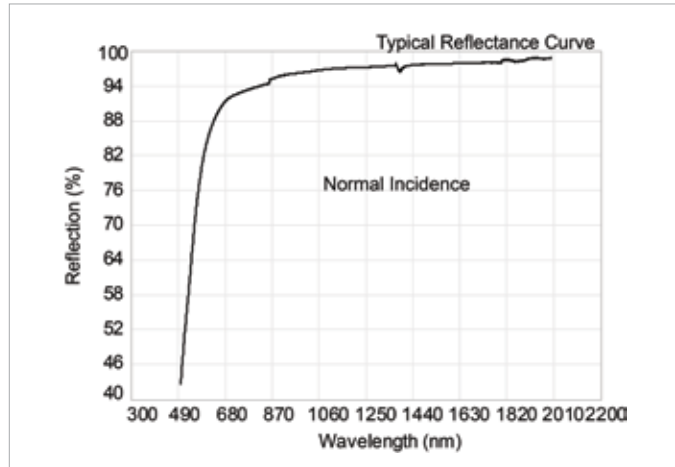

Protected gold coating at 0°

PROTECTED GOLD FLAT MIRRORS						
Shape	Ø (mm)	□ (mm)	t (mm)	Clear Aperture (mm)	Surface Figure (S1)	PART NUMBER
Round	12.7	—	6.35	10.8	< λ/10	PG-PM-0525-C
Round	25.4	—	6.35	21.6	< λ/10	PG-PM-1025-C
Round	50.8	—	9.53	43.2	< λ/10	PG-PM-2037-C
Round	76.2	—	12.7	64.8	< λ/10	PG-PM-3050-C

FEMTOSECOND BEAMSPLITTER: FABS

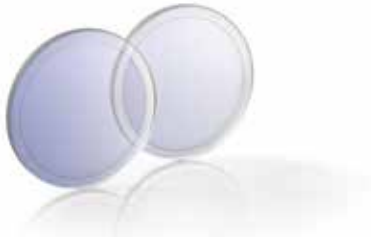

Femtosecond autocorrelator beamsplitters are broadband, 50% all-dielectric beamsplitters. They are useful in many types of pump-probe experiments and in the construction of anti-resonant ring configurations. They are essentially lossless and extremely durable. Both are advantages over partially reflecting metal coatings.

As with virtually all dielectric coated optics, the s-polarized version is broader than p-polarized. CVI Laser Optics can produce FABS in other than 50:50 with excellent phase characteristics.

Specifications

Product Code: **FABS**

Optical Material:

Standard Grade Corning 7980 1-D (Fused Silica)

Diameter: 25.4mm +0/-0.25mm

Thickness: 1.0mm ±0.25mm

Wedge Tolerance: ≤10 arc sec

Chamfer: 0.35mm leg width at 45° nominal

Surface Quality: 10-5 scratch-dig per MIL-PRF-13830b

Surface Figure: $\lambda/10$ p-v at 633nm before coating; after coating on select substrates

Clear Aperture: ≥85% of central diameter

Transmission: [1-R] first surface

Angle of Incidence: 45°

Polarization: Specify s- or p-polarization.

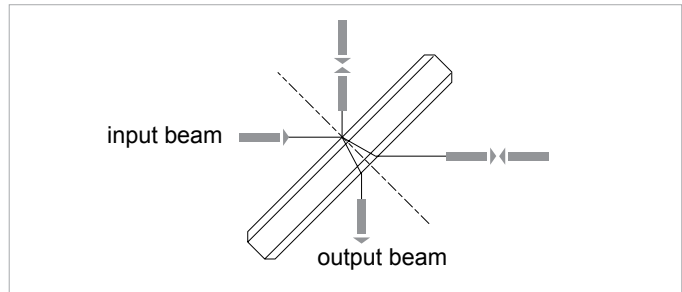

FEMTOSECOND BEAMSPLITTERS		
Wavelength (nm)	Polarization	PART NUMBER
790.0	P	FABS-790-45P-PW1-1004-UV
790.0	S	FABS-790-45S-PW1-1004-UV
800.0	P	FABS-800-45P-PW1-1004-UV
800.0	S	FABS-800-45S-PW1-1004-UV
1550.0	S	FABS-1550-45S-PW1-1004-UV

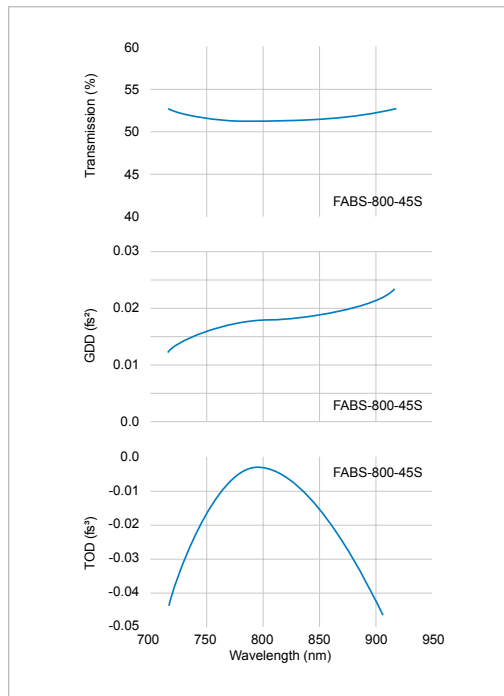

S-Polarized

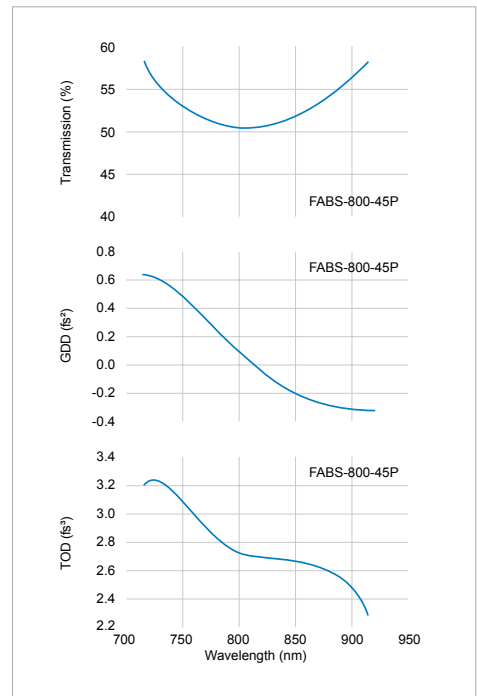

P-Polarized

HIGH ENERGY BROADBAND POLARIZING CUBE BEAMSPLITTERS: PBSK



Specifications

Product Code: **PBSK**

Optical Material:

Standard Grade Corning 7980 1-D (Fused Silica)

Edge Dimension Tolerance (X,Y): $\pm 0.25\text{mm}$

Surface Quality: 20-10 scratch-dig per MIL-PRF-13830b

Transmitted Wavefront Error (TWE): $< \lambda/4$ p-v at 633nm

Clear Aperture: $\geq 85\%$ of central dimension

Extinction Ratio: $T_p/T_s > 1000:1$

Anti-reflection Coating:

$R_{\text{avg}} \leq 0.50\%$, all entrance and exit surfaces

Damage Threshold:

Pulsed: 5 J/cm², 20ns, 20 Hz at 1064nm

cw: 1 MW/cm² at 1064nm

An alternative to calcite and Brewster angle polarizers, the PBSK is an optimal solution for high-energy broadband or multi-line systems. Unlike cemented cube polarizers, the PBSK is optically contacted, coated with all-dielectric materials and manufactured from fused silica to ensure high transmission and high damage threshold.

To avoid damage when using a high power laser, be sure to orient the cube so that the beam enters through the prism marked with the dot.

- ▶ Designed for Pulse Lengths > 15 fs
- ▶ Contact CVI Laser Optics for other designs between 230nm and 2100nm

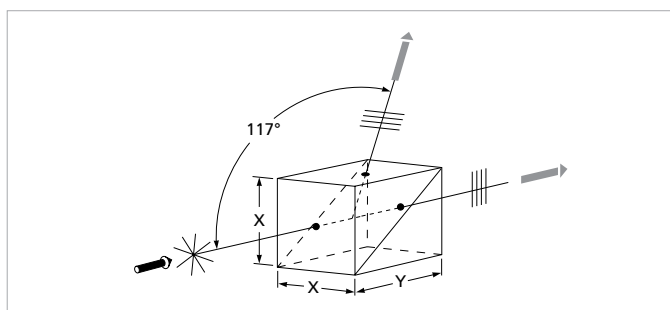

PBSK high-energy broadband polarizing beamsplitter cubes

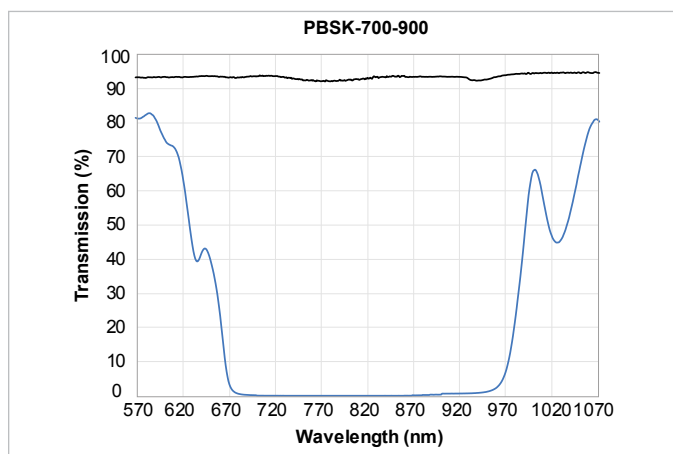

HIGH ENERGY BROADBAND POLARIZING CUBE BEAMSPLITTERS

X x Y (mm)	PART NUMBER
12.7x17.5	PBSK-700-900-050
15.4x35.3	PBSK-700-900-100

