

# MIRRORS

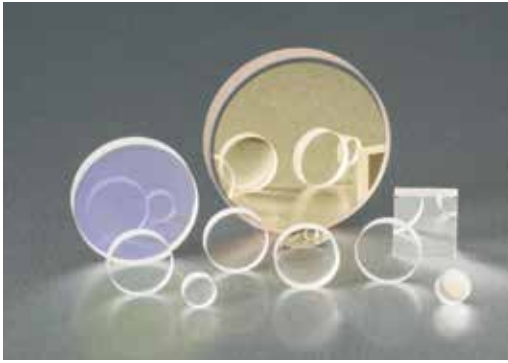

Our mirrors are available in partial or high reflecting configurations, narrow or large bandwidth, and are designed for specific laser technology including, but not limited to: excimer, gas, Nd:YAG, Nd:YLF, laser diode, diode-pumped solid-state; and Ti:Sapphire lasers. With an impressive complement of reflective coatings and substrates, our mirrors can be utilized in the deep UV, all the way up to the infrared with either dielectric or metallic coatings. Our dielectric mirrors are designed for high powered applications utilizing laser grade substrates.

Don't see a mirror configuration that meets your needs? We also offer an extensive range of mirror substrates that can be ordered in production quantities with a CVI specific coating.

SELECTION GUIDE ..... 4

PARTIAL REFLECTORS (OUTPUT COUPLERS) ..... 6

NARROWBAND LASER LINE MIRRORS ..... 8

BROADBAND DIELECTRIC MIRRORS ..... 17

METAL COATED MIRRORS ..... 20

UNCOATED MIRROR SUBSTRATES ..... 27

**Don't see exactly what you are looking for?**

CVI Laser Optics specializes in prototype to volume production manufacturing!

Give us a call and we will be honored to assist you with your custom needs.

**NOTES:**

---



---



---



---



---



---



---



---



---



---



---



---



---



---



---



---



---



---



---



---



---



---

## SELECTION GUIDE

PRODUCT TYPE	WAVELENGTHS	REFLECTANCE	OPERATING CONDITIONS	PAGE
<b>Narrowband Partial Reflecting Mirrors</b>				
HIGH ENERGY PARTIAL REFLECTING LASER MIRRORS: <b>PR1</b>	Wavelengths from 190nm to 2100nm	See page 6 Range: 30% to 99%	20 J/cm <sup>2</sup> , 20ns, 20Hz at 1064nm, 10 MW/cm <sup>2</sup> at 1064nm	6
<b>Narrowband Laser Line Mirrors</b>				
TUNABLE LASER LINE MIRRORS: <b>TLM1</b>	Wavelengths from 190nm to 2100nm	R ≥ 99.0% at 0° R ≥ 98.5% at 45°, P-Pol R ≥ 99.0% at 45°, UNP R ≥ 99.5% at 45°, S-Pol	20 J/cm <sup>2</sup> , 20ns, 20Hz at 1064nm, 10 MW/cm <sup>2</sup> at 1064nm	8
FIBER LASER MIRRORS: <b>FLM</b>	343, 515, 1030, 1064, 1070, and 1550nm	R ≥ 99.0% at 0° R ≥ 99.0% at 45°, UNP	20 J/cm <sup>2</sup> , 20ns, 20Hz at 1064nm, 10 MW/cm <sup>2</sup> at 1064nm	14
EXCIMER LASER MIRRORS: <b>ARF</b>	193	R ≥ 97% at 0° R ≥ 96.0% at 45° UNP	1 J/cm <sup>2</sup> , 20ns pulse at 193nm	9
Nd:YAG MIRRORS: <b>Y5</b>	213	R ≥ 97.0% at 0° R ≥ 97.0% at 45°, UNP	3 J/cm <sup>2</sup> , 8ns pulse at 248nm	12
EXCIMER LASER MIRRORS: <b>KRF</b>	248	R ≥ 99.5% at 0° R ≥ 99.0% at 45°, UNP	3 J/cm <sup>2</sup> , 8ns pulse at 248nm	9
Nd:YAG / Nd:YLF LASER MIRRORS: <b>Y4</b>	262-266	R ≥ 99.9% at 0° R ≥ 99.6% at 45°, P-Pol R ≥ 99.8% at 45°, UNP R ≥ 99.9% at 45°, S-Pol	10 J/cm <sup>2</sup> , 20ns, 20Hz at 266nm	10
Nd:YAG / Nd:YLF LASER MIRRORS: <b>Y3</b>	349-355	R ≥ 99.9% at 0° R ≥ 99.6% at 45°, P-Pol R ≥ 99.8% at 45°, UNP R ≥ 99.9% at 45°, S-Pol	15 J/cm <sup>2</sup> , 20ns, 20Hz at 355nm	10
Nd:YAG / Nd:YLF LASER MIRRORS: <b>Y2</b>	523-532	R ≥ 99.9% at 0° R ≥ 99.6% at 45°, P-Pol R ≥ 99.8% at 45°, UNP R ≥ 99.9% at 45°, S-Pol	20 J/cm <sup>2</sup> , 20ns, 20Hz at 532nm	10
Nd:YAG / Nd:YLF LASER MIRRORS: <b>Y1</b>	1047-1064	R ≥ 99.9% at 0° R ≥ 99.6% at 45°, P-Pol R ≥ 99.8% at 45°, UNP R ≥ 99.9% at 45°, S-Pol	25 J/cm <sup>2</sup> , 20ns, 20Hz at 1064nm	10
ION BEAM SPUTTERED Nd:YAG LASER MIRRORS: <b>Y1S, Y2S, Y3S, Y4S</b>	266, 355, 532, 1064	R ≥ 99.9% at 0° R ≥ 99.9% at 45°, P-Pol R ≥ 99.9% at 45°, S-Pol	40 J/cm <sup>2</sup> , 20ns, 20Hz at 1064nm	13
<b>Dual Band Laser Line Mirrors</b>				
Nd:YAG 1064/532nm DUAL WAVELENGTH MIRRORS: <b>HM</b>	1064/532	R ≥ 99% at 1064 and 532nm	8 J/cm <sup>2</sup> , 20ns, 20Hz at 1064nm, 3 J/cm <sup>2</sup> , 20ns, 20Hz at 532nm	15
Nd:YAG 1064/633nm DUAL WAVELENGTH MIRRORS: <b>YH</b>	1064/633	R ≥ 99% at 1064nm R ≥ 80% at 633nm	8 J/cm <sup>2</sup> , 20ns pulse at 1064nm	16

## SELECTION GUIDE

PRODUCT TYPE	WAVELENGTHS	REFLECTANCE	OPERATING CONDITIONS	PAGE
<b>Broadband Mirrors</b>				
TUNABLE BROADBAND MIRRORS: <a href="#">TLM2</a>	Wavelengths from 450nm to 2100nm	R > 99.5% at 0° incidence R >99.0% at 45° incidence	500 mJ/cm <sup>2</sup> , 20ns, 20Hz at 1064nm	18
MAXBRITETM BROADBAND MIRRORS: <a href="#">MPQ</a>	245 – 390 (UV) 420 – 700 (VIS)	R <sub>avg</sub> ≥ 98% from 245 – 390nm at 0° - 45° R <sub>avg</sub> ≥ 98% from 420 – 700nm at 0° - 45°	0.5 J/cm <sup>2</sup> , 10ns at 532nm	19
TI:SAPPHIRE ULTRAFAST MIRRORS: <a href="#">TLMB</a>	740 – 860	R > 99.0% from 740 – 860nm	8 J/cm <sup>2</sup> , 300 ps, 20Hz at 800nm	17
<b>Metal Coated Mirrors</b>				
VACUUM UV ALUMINUM MIRRORS: <a href="#">VUVA</a>	157 – 190	R > 85% at 157nm by design	Low Power Applications	20
DEEP UV ALUMINUM MIRRORS: <a href="#">DUVA</a>	193 – 1200	R > 90% at 193nm R <sub>avg</sub> ≥ 85% at 400 – 1200nm	Low Power Applications	21
UV ENHANCED ALUMINUM FLAT MIRRORS: <a href="#">PAUV</a>	250 – 600	R <sub>avg</sub> ≥ 85% (250 – 600nm)	Low Power Applications	22
PROTECTED ALUMINUM FLAT MIRRORS: <a href="#">PAV</a>	400 – 800	R <sub>avg</sub> ≥ 87% (400 – 800nm)	Low Power Applications	23
ENHANCED ALUMINUM FLAT MIRRORS: <a href="#">EAV</a>	450 – 650	R <sub>avg</sub> ≥ 92% (450 – 650nm)	Low Power Applications	24
PROTECTED SILVER FLAT MIRRORS: <a href="#">PS</a>	400 – 20,000	R <sub>avg</sub> ≥ 95% (400nm to 20 μm)	Low Power Applications	25
PROTECTED GOLD FLAT MIRRORS: <a href="#">PG</a>	650 – 20,000	R <sub>avg</sub> ≥ 95.5% (650 – 1700nm) R <sub>avg</sub> ≥ 98.0% (2 – 16 μm)	Low Power Applications	26
<b>Uncoated Mirror Substrates</b>				
PRODUCT TYPE	MATERIAL			PAGE
CONVEX SPHERICAL FUSED SILICA MIRROR BLANKS: <a href="#">SMCX-UV</a>	Standard Grade Corning 7980 1-D (Fused Silica)			27
CONCAVE SPHERICAL MIRROR BLANKS: <a href="#">SMCC-C</a> , <a href="#">SMCC-UV</a>	N-BK7 or Standard Grade Corning 7980 1-D (Fused Silica)			28
PLANE ROUND MIRROR BLANKS: <a href="#">PM-C</a> , <a href="#">PM-UV</a>	N-BK7 or Standard Grade Corning 7980 1-D (Fused Silica)			29
PLANE SQUARE MIRROR BLANKS: <a href="#">SQM-C</a> , <a href="#">SQM-UV</a>	N-BK7 or Standard Grade Corning 7980 1-D (Fused Silica)			30
PLANE RECTANGULAR MIRROR BLANKS: <a href="#">RM-UV</a>	Standard Grade Corning 7980 1-D (Fused Silica)			31

## HIGH ENERGY PARTIAL REFLECTING LASER MIRRORS: PR1



## Specifications

Product Code: PR1

## Substrate Material:

 $\lambda \leq 450\text{nm}$ : Standard Grade Corning 7980 1-D (Fused Silica) $\lambda > 450\text{nm}$ : N-BK7Diameter Tolerance:  $+0/-0.25\text{mm}$ Thickness Tolerance:  $\pm 0.25\text{mm}$ Wedge:  $\leq 5$  arc minutes (plano substrates only)Concentricity:  $\pm 0.05\text{mm}$  (spherical substrates only)Radius Tolerance:  $\pm 0.5\%$  (spherical substrates only)

Chamfer: 0.35mm leg width at 45° nominal

S1 Surface Figure:  $< \lambda/10$  p-v at 633nm before coating; after coating on select substrates

S1 Surface Quality: 10-5 scratch-dig per MIL-PRF-13830b (at 100W)

S2 Surface Figure:  $< \lambda/10$  p-v at 633nm before coating; after coating on select substrates

S2 Surface Quality: 10-5 scratch-dig per MIL-PRF-13830b (at 100W)

## Transmitted Wavefront

Distortion:  $< \lambda/10$  p-v at 633nmClear Aperture:  $\geq 85\%$  of central diameter

Angle of Incidence: 0°

Adhesion and Durability: Per MIL-C-48497a

S1 Coating: See table on page 7

S2 AR Coating:  $R \leq 0.25\%$  at center wavelength

## Damage Threshold:

Fused Silica: 20 J/cm<sup>2</sup>, 20ns, 20Hz at 1064nmN-BK7: 10 J/cm<sup>2</sup>, 20ns, 20Hz at 1064nm

Other reflectance values and substrate dimensions available upon request. Standard partial reflectors have an anti-reflection coating on the second surface.

- ▶ Custom reflection options from 10% to 99%
- ▶ Contact an applications engineer for OEM options

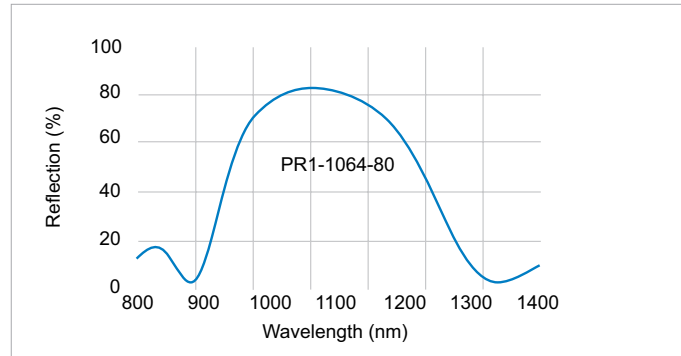

Reflectivity vs wavelength of PR1-1064-80 at 0° incidence angle

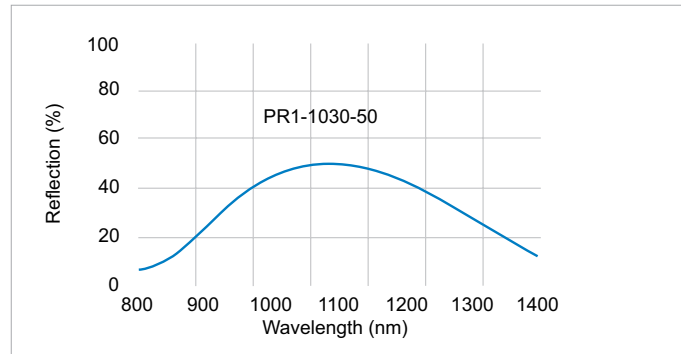

Reflectivity vs wavelength of PR1-1030-50 at 0° incidence angle

Visit [cvilaseroptics.com](http://cvilaseroptics.com) for additional traces.

## BUILD YOUR PART NUMBER

STEP-1	STEP-2	STEP-3	STEP-4
PRODUCT CODE	CENTER WAVELENGTH (nm)	REFLECTANCE (%)	SIZE CODE/RADII/WEDGE
PR1	800	95	0525

EXAMPLES: PR1-800-95-0525 (FLAT); PR1-800-95-0525-0.10CC (RADII); PR1-800-95-IF-0525-UV (WEDGE)

CHOOSE FROM THE OPTIONS BELOW.

### 1. PRODUCT CODE

PR1
-----

### 2. CENTER WAVELENGTH (nm)

532	633	800	1030	1064	1550
-----	-----	-----	------	------	------

### 3. REFLECTANCE (%)

30 ±5.0	70 ±4.0	90 ±2.0	98 ±1.0
50 ±5.0	80 ±4.0	95 ±1.5	99 ±0.5

### 4. SIZE CODE

SIZE CODE	DIAMETER (mm)	THICKNESS (mm)	STANDARD OPTIONS
0525	12.7	6.35	Flat, Radius or Wedge
1025	25.4	6.35	Flat, Radius or Wedge
2037	50.8	9.53	Flat or Wedge

### 4. RADIUS OF CURVATURE (m)

SIZE CODE	DIAMETER (mm)	RADII OPTIONS (m), CC = concave						
0525	12.7	0.10CC	0.25CC	0.50CC	1.00CC			
1025	25.4	0.10CC	0.25CC	0.50CC	1.00CC	3.00CC	5.00CC	10.00CC

### 4. WEDGE OPTION (for wedge option omit size and radius of curvature options)

SUBSTRATE PART #	DIAMETER (mm)	THICKNESS (mm)	WEDGE (minutes)	MATERIAL
IF-0525-UV	12.7	6.35	30±5	Fused Silica
IF-1025-UV	25.4	6.35	30±5	Fused Silica
IF-2037-UV	50.8	9.53	30±5	Fused Silica

# HIGH POWER TUNABLE LASER LINE MIRRORS: TLM1



## Specifications

Product Code: **TLM1**

**Substrate Material:**

$\lambda < 450\text{nm}$ : Standard Grade Corning 7980 1-D (Fused Silica)

$\lambda > 450\text{nm}$ : N-BK7

**Diameter Tolerance:** +0/-0.25mm

**Thickness Tolerance:**  $\pm 0.25\text{mm}$

**Wedge:**  $\leq 5$  arc minutes

**Chamfer:**

$\emptyset \leq 50.8\text{mm}$ : 0.35mm leg width at 45° nominal  
 $\emptyset > 50.8\text{mm}$ : 0.85mm leg width at 45° nominal

**S1 Surface Figure:**  $< \lambda/10$  p-v at 633nm before coating: after coating on select substrates

**S1 Surface Quality:** 10-5 scratch-dig per MIL-PRF-13830b (at 100W)

**S2 Surface Quality:** Commercial polish

**Concentricity:**  $\leq 0.05\text{mm}$  (spherical substrates only)

**Radius Tolerance:**  $\pm 0.5\%$  (spherical substrates only)

**Clear Aperture:**  $\geq 85\%$  of central diameter

**Angle of Incidence:** 0° or 45° options

**Adhesion and Durability:** Per MIL-C-48497a

**Reflectance:**

R  $\geq 99.0\%$  at 0°

R  $\geq 98.5\%$  at 45°, P-Pol

R  $\geq 99.0\%$  at 45°, UNP

R  $\geq 99.5\%$  at 45°, S-Pol

**Damage Threshold:**

**Pulsed:**

20 J/cm<sup>2</sup>, 20ns, 20Hz at 1064nm

0.55 J/cm<sup>2</sup>, 50 fsec, 50Hz at 800nm

5.0 J/cm<sup>2</sup>, 10ns, 20Hz at 532nm

3.0 J/cm<sup>2</sup>, 7ns, 20Hz at 266nm

**Continuous Wave:** 10 MW/cm<sup>2</sup> at 1064nm

**Center Wavelength Tolerance:**  $\pm 3\%$

### TYPICAL BANDWIDTH FOR TLM1 MIRRORS

Center wave-length (nm)	R>99% 0°	R>99% 45°S	R> 98% 45°P
200	10*	12*	—
400-405	50	64	31
780	85	109	61
800	88	110	62
1030	99	123	74
1550	124	154	94

\* R > 97.0%

### BUILD YOUR PART NUMBER

STEP-1	STEP-2	STEP-3	STEP-4	STEP-5
PRODUCT CODE	CENTER WAVELENGTH	ANGLE OF INCIDENCE	SIZE CODE	RADII OPTIONS
TLM1	800	0	1025	1.00CC

EXAMPLE: TLM1-800-0-1025-1.00CC

### CHOOSE FROM THE OPTIONS BELOW.

#### 1. PRODUCT CODE

TLM1
------

#### 2. CENTER WAVELENGTH (nm)

200	400-405	780	800	1030	1550
-----	---------	-----	-----	------	------

#### 3. ANGLE OF INCIDENCE in Degrees

0	0 degrees (normal incidence)
45	45 degrees

#### 4. FLAT SIZE CODE

Flat Size Code	Diameter (mm)	Thickness (mm)	Standard Options
0525	12.7	6.35	Flat or Radius
0725	19.1	6.35	Flat Only
1025	25.4	6.35	Flat or Radius
2037	50.8	9.53	Flat Only
3050	76.2	12.7	Flat Only
4050	101.6	12.7	Flat Only

#### 5. RADIUS OF CURVATURE (m)

SIZE CODE	Diameter (mm)	RADII OPTIONS (m), cc = concave		RADII OPTIONS (m), cx = convex
0525	12.7	0.10CC	0.75CC	
		0.25CC	1.00CC	
		0.50CC		
1025	25.4	0.10CC	1.50CC	0.30CX
		0.25CC	2.00CC	0.50CX
		0.50CC	3.00CC	1.00CX
		0.75CC	5.00CC	
		1.00CC	10.00CC	

For Nd:YAG/Nd:YLF wavelengths see page 11  
 For ArF and KrF wavelengths see page 9

Please see page T-28 for High Reflection Coating Traces.

# EXCIMER LASER MIRRORS: ARF, KRF



## Specifications

Product Code: **ARF, KRF**

**Substrate Material:**

Standard Grade Corning 7980 1-D (Fused Silica)

**Diameter Tolerance:** +0/-0.25mm

**Thickness Tolerance:** ±0.25mm

**Wedge:** ≤ 5 arc minutes

**Chamfer:**

Ø ≤ 50.8mm: 0.35mm leg width at 45° nominal

Ø > 50.8mm: 0.85mm leg width at 45° nominal

**S1 Surface Figure:** < λ/10 p-v at 633nm before coating; after coating on select substrates

**S1 Surface Quality:** 10-5 scratch-dig per MIL-PRF 13830b (at 100W)

**S2 Surface Quality:** Commercial polish

**Clear Aperture:** ≥ 85% of central diameter

**Adhesion and Durability:** Per MIL-C-48497a

**Angle of Incidence:** 45° only

**Reflectance (at 193nm):**

R ≥ 96.0% at 45°, UNP

**Reflectance (at 248nm):**

R > 99.0% at 45°, UNP

**Damage Threshold:**

1 J/cm<sup>2</sup>, 20ns pulse at 193nm

3 J/cm<sup>2</sup>, 8ns pulse at 248nm

We offer an extensive range of high-quality excimer laser mirrors specifically designed for use with today's high-energy excimer laser applications. Our unique coatings have continued to outperform the industry standards and provide our customers with optics for the most demanding laser environments.

► Contact an applications engineer for OEM options

BUILD YOUR PART NUMBER		
STEP-1	STEP-2	STEP-3
PRODUCT CODE	SIZE CODE	ANGLE OF INCIDENCE
ARF	1537	45
EXAMPLE: ARF-1537-45		

CHOOSE FROM THE OPTIONS BELOW.

1. PRODUCT CODE	LASER TYPE	WAVELENGTH (nm)
ARF	ArF Solid State Excimer Laser	193
KRF	KrF Solid State Excimer Laser	248

2. SIZE CODE	DIAMETER (mm)	THICKNESS (mm)
1025	25.4	6.35
1537	38.1	9.53
2037	50.0	9.53
3050	76.2	12.7

3. ANGLE OF INCIDENCE in Degrees	
45	45 degrees

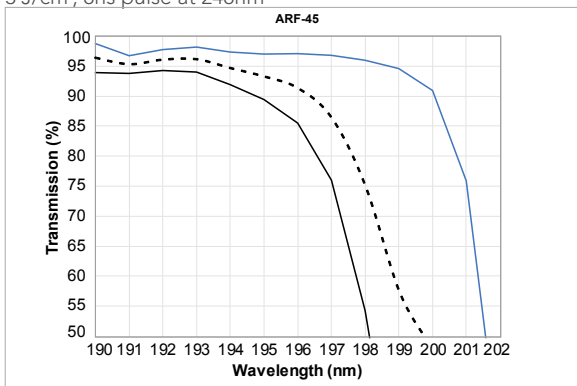

Reflection vs wavelength of 193nm excimer laser mirror for 0° and 45° designs. Minimum reflectance > 97% at 0°, > 96.0% at 45° UNP, > 94.0% at 45° P-Pol, and > 97.0% at 45° S-Pol

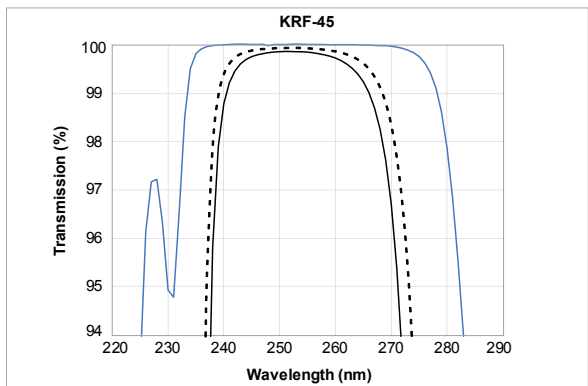

Reflection vs wavelength of 248nm excimer laser mirror for 0° and 45° designs. Minimum reflectance > 99.5% at 0° and > 99.0% at 45° UNP

P-POL: — UNP: - - - S-POL: — 0°: - · - · -

## HIGH POWER Nd:YAG / Nd:YLF LASER MIRRORS: Y1, Y2, Y3, Y4



### Specifications

Product Code: **Y1, Y2, Y3, Y4**

**Substrate Material:**

Standard Grade Corning 7980 1-D (Fused Silica)

**Diameter Tolerance:** +0/-0.25mm

**Thickness Tolerance:** ±0.25mm

**Wedge:** ≤ 5 arc minutes (flat substrates only)

**Chamfer:**

Ø ≤ 50.8mm: 0.35mm leg width at 45° nominal

Ø > 50.8mm: 0.85mm leg width at 45° nominal

**Concentricity:** ±0.05mm (spherical substrates only)

**Radius Tolerance:** ±0.5% (spherical substrates only)

**S1 Surface Figure:** < λ/10 p-v at 633nm before coating; after coating on select substrates

**S1 Surface Quality:** 10-5 scratch-dig per MIL-PRF-13830b (at 100W)

**S2 Surface Quality:** Commercial polish

**Clear Aperture:** ≥ 85% of central diameter

**Angle of Incidence:** 0° or 45° options

**Reflectance:**

R ≥ 99.9% at 0°

R ≥ 99.6% at 45°, P-Pol

R ≥ 99.8% at 45°, UNP

R ≥ 99.9% at 45°, S-Pol

**Adhesion and Durability:** Per MIL-C-675c and MIL-C-48497a

**Damage Threshold:**

**Pulsed:**

25 J/cm<sup>2</sup>, 20ns, 20Hz at 1064nm

20 J/cm<sup>2</sup>, 20ns, 20Hz at 532nm

15 J/cm<sup>2</sup>, 20ns, 20Hz at 355nm

10 J/cm<sup>2</sup>, 20ns, 20Hz at 266nm

**cw:** 10 MW/cm<sup>2</sup> at 1064nm

**USABLE BANDWIDTH (R<sub>avg</sub> ≥ 99.0%):**

Y1	1020 - 1100nm
Y2	510 - 560nm
Y3	340 - 370nm
Y4	255 - 275nm

BUILD YOUR PART NUMBER			
STEP-1	STEP-2	STEP-3	STEP-4
PRODUCT CODE	SIZE CODE	ANGLE OF INCIDENCE	RADII OPTIONS
Y1	1025	0	1.00CC
EXAMPLE: Y1-1025-0-1.00CC			

CHOOSE FROM THE OPTIONS BELOW.

1. PRODUCT CODE	LASER TYPE	WAVELENGTH (nm)
Y1	Nd:YAG / Nd:YLF	1047-1064
Y2	Nd:YAG / Nd:YLF second harmonic	523-532
Y3	Nd:YAG / Nd:YLF third harmonic	349-355
Y4	Nd:YAG / Nd:YLF fourth harmonic	262-266

2. SIZE CODE	DIAMETER (mm)	THICKNESS (mm)
0525	12.7	6.35
1025	25.4	6.35
1537	38.1	9.53
2037	50.8	9.53
3050	76.2	12.7
4050	101.6	12.7

3. ANGLE OF INCIDENCE in Degrees	
0	0 degrees (normal incidence)
45	45 degrees

4. RADIUS OF CURVATURE (m)				
SIZE CODE	Diameter (mm)	RADII OPTIONS (m), cc = concave		RADII OPTIONS (m), cx = convex
0525	12.7	0.10CC	0.75CC	
		0.25CC	1.00CC	
		0.50CC		
1025	25.4	0.10CC	1.50CC	0.30CX
		0.25CC	2.00CC	0.50CX
		0.50CC	3.00CC	1.00CX
		0.75CC	5.00CC	
		1.00CC	10.00CC	



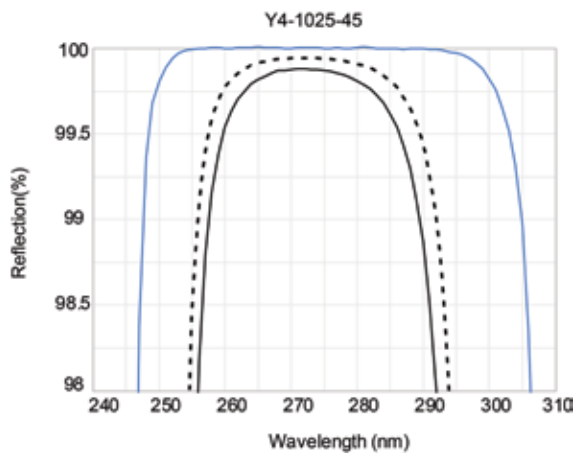
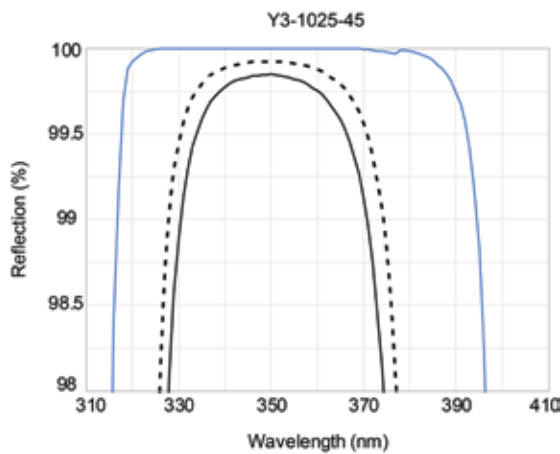
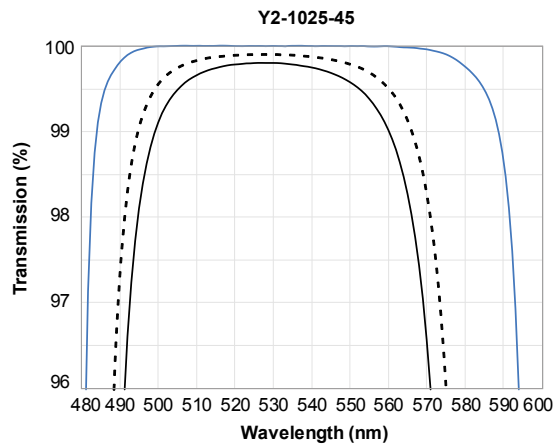
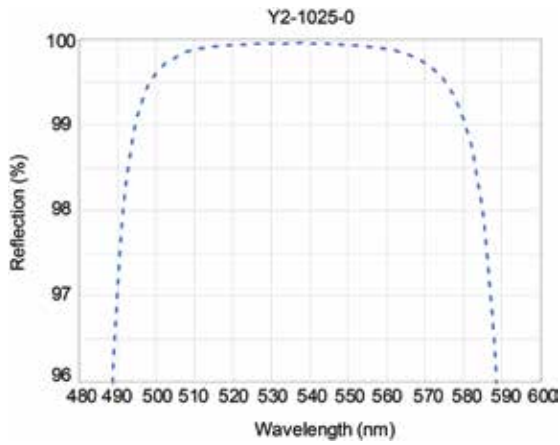
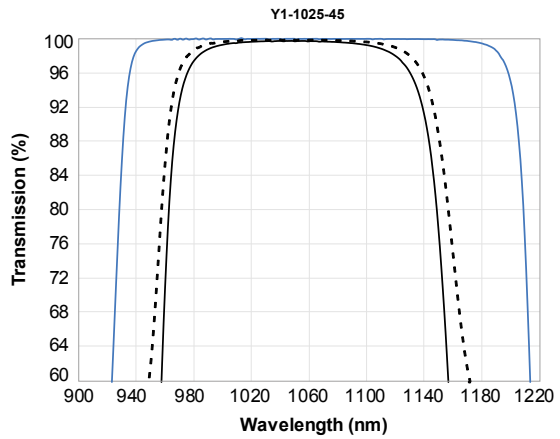
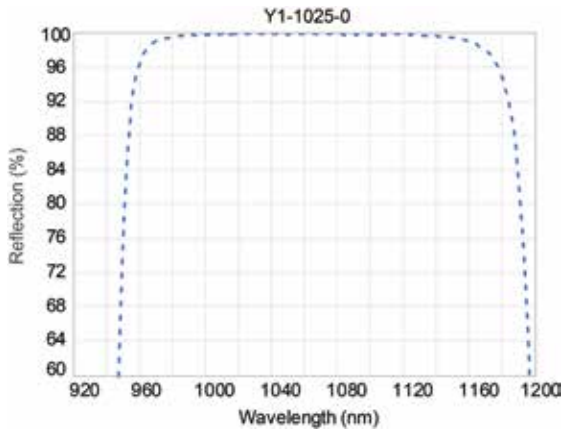

\* Traces based on actual performance; not theoretical

P-POL: — UNP: - - - - S-POL: — 0°: - - - -

# HIGH POWER Nd:YAG LASER MIRROR: Y5



## Specifications

Product Code: **Y5**

**Substrate Material:**  
Standard Grade Corning 7980 1-D (Fused Silica)

**Diameter Tolerance:** +0/-0.25mm

**Thickness Tolerance:** ±0.25mm

**Wedge:** ≤ 5 arc minutes

**Chamfer:** 0.35mm leg width at 45° nominal

**S1 Surface Figure:** <math>\lambda/10</math> p-v at 633nm before coating; after coating on select substrates

**S1 Surface Quality:** 10-5 scratch-dig per MIL-PRF-13830b (at 100W)

**S2 Surface Quality:** Commercial polish

**Clear Aperture:** ≥ 85% of central diameter

**Angle of Incidence:** 0° or 45° options

**Reflectance:**

- R ≥ 97.0% at 0°
- R ≥ 95.0% at 45°, P-Pol
- R ≥ 97.0% at 45°, UNP
- R ≥ 98.5% at 45°, S-Pol

**Adhesion and Durability:** Per MIL-C-48497a

**Damage Threshold:**

**Pulsed:**  
3 J/cm<sup>2</sup>, 8ns, at 248nm

BUILD YOUR PART NUMBER		
STEP-1	STEP-2	STEP-3
PRODUCT CODE	SIZE CODE	ANGLE OF INCIDENCE
Y5	1025	45
EXAMPLE: Y5-1025-45		

CHOOSE FROM THE OPTIONS BELOW.

1. PRODUCT CODE	LASER TYPE	WAVELENGTH (nm)
Y5	Nd:YAG fifth harmonic	213

2. SIZE CODE	DIAMETER (mm)	THICKNESS (mm)
0525	12.7	6.35
1025	25.4	6.35
2037	50.8	9.53

3. ANGLE OF INCIDENCE in Degrees	
0	Normal incidence
45	45 degrees

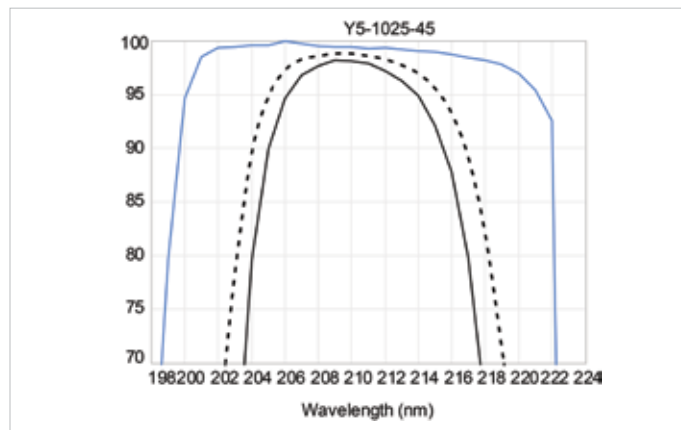
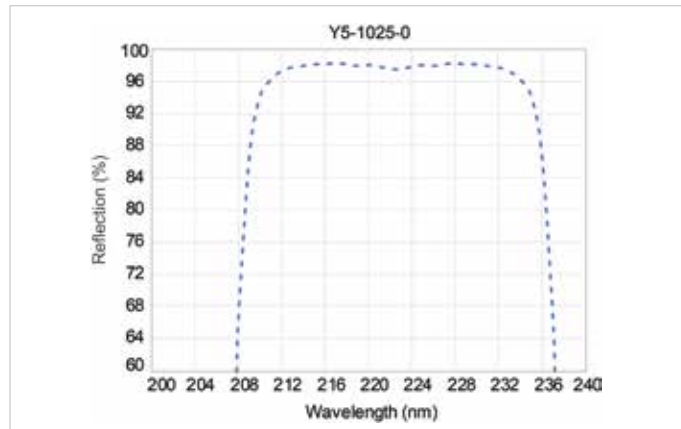

P-POL: — UNP: - - - S-POL: — 0°: ·····

## ION BEAM SPUTTERED Nd: YAG LASER MIRRORS: Y1S, Y2S, Y3S, Y4S



- ▶ High reflectivity and laser damage threshold
- ▶ Minimal coating shift; high environmental stability
- ▶ Ideal for high-power Nd:YAG and fiber laser applications

### Specifications

Product Code: **Y1S, Y2S, Y3S, Y4S**

**Substrate Material:**

Standard Grade Corning 7980 1-D (Fused Silica)

**Diameter Tolerance:** +0/-0.25 mm

**Thickness Tolerance:** ±0.25 mm

**Wedge:** ≤ 5 arc min

**Chamfer:** 0.35 mm leg width at 45° typical

**S1 Surface Figure:** < λ/10 p-v at 633 nm before coating

**S1 Surface Quality:** 10-5 scratch and dig per MIL-PRF 13830b

**S2 Surface Quality:** Commercial polish

**Clear Aperture:** ≥ 85% of central diameter

**Angle of Incidence:** 0° or 45° options

**Adhesion and Durability:** Per MIL-PRF-13830b

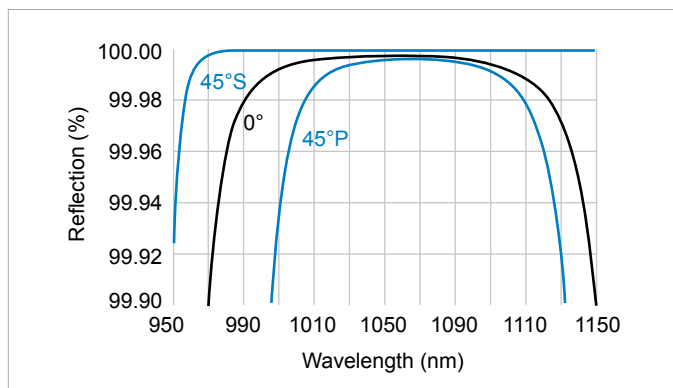

Reflectivity vs wavelength of Y1S low loss Nd:YAG laser mirror at 45° and 0° incidence angle design

ION BEAM SPUTTERED ND:YAG LASER MIRRORS						
Wavelength (nm)	Reflectivity	Incidence Angle	Damage Threshold	Ø (mm)	t (mm)	PART NUMBER
1064	≥ 99.9% at 0°	0°	40 J/cm <sup>2</sup> @ 1064nm	25.4	6.35	<b>Y1S-1025-0</b>
1064	≥ 99.9% at 45° (both S & P)	45°	40 J/cm <sup>2</sup> @ 1064nm	25.4	6.35	<b>Y1S-1025-45</b>
532	≥ 99.9% at 0°	0°	8 J/cm <sup>2</sup> @ 532nm	25.4	6.35	<b>Y2S-1025-0</b>
532	≥ 99.9% at 45° (both S & P)	45°	8 J/cm <sup>2</sup> @ 532nm	25.4	6.35	<b>Y2S-1025-45</b>
355	≥ 99.9% at 0°	0°	3 J/cm <sup>2</sup> @ 355nm	25.4	6.35	<b>Y3S-1025-0</b>
355	≥ 99.9% at 45° (both S & P)	45°	3 J/cm <sup>2</sup> @ 355nm	25.4	6.35	<b>Y3S-1025-45</b>
266	≥ 99.9% at 0°	0°	2 J/cm <sup>2</sup> @ 266nm	25.4	6.35	<b>Y4S-1025-0</b>
266	≥ 99.9% at 45° (both S & P)	45°	2 J/cm <sup>2</sup> @ 266nm	25.4	6.35	<b>Y4S-1025-45</b>

## FIBER LASER MIRRORS: FLM



### Specifications

Product Code: **FLM**

**Substrate Material:**

Standard Grade Corning 7980 1-D (Fused Silica)

**Diameter Tolerance:** +0/-0.25mm

**Thickness Tolerance:** ±0.25mm

**Wedge:** ≤ 5 arc minutes

**Chamfer:** 0.35mm leg width at 45° nominal

**S1 Surface Figure:** <math>\lambda/10</math> p-v at 633nm before coating; after coating on select substrates

**S1 Surface Quality:** 10-5 scratch-dig per MIL-PRF-13830b (at 100W)

**S2 Surface Quality:** Commercial polish

**Clear Aperture:** ≥ 85% of central diameter

**Adhesion and Durability:** Per MIL-C-48497a

**Angle of Incidence:** 0° or 45° options

**Reflectance:**

R ≥ 99.0% at 0°

R ≥ 98.5% at 45°, P-Pol

R ≥ 99.0% at 45°, UNP

R ≥ 99.5% at 45°, S-Pol

**Damage Threshold:**

**Pulsed:** 20 J/cm<sup>2</sup>, 20ns, 20Hz at 1064nm

**cw:** 10 MW/cm<sup>2</sup> at 1064nm

- ▶ Applications include: laser marking, precision micromachining, optical tweezers, and Diode-Pumped Solid-State lasers
- ▶ Other center wavelengths and substrate dimensions are available for OEM applications

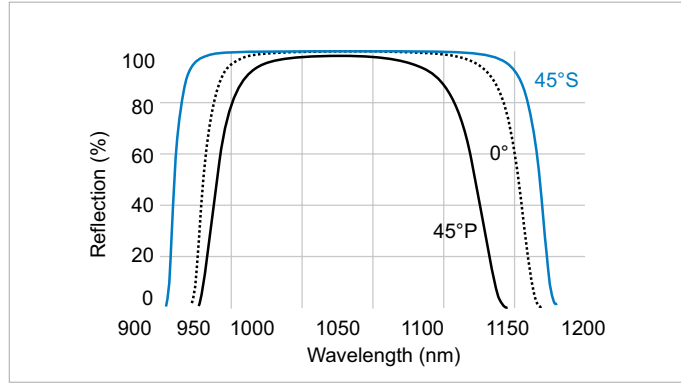

Reflectivity vs wavelength of FLM fiber laser mirror at 1030nm for 0° and 45° designs

Visit [cvilaseroptics.com](http://cvilaseroptics.com) for additional traces

FIBER LASER MIRRORS				
Wavelength (nm)	Incidence Angle	Ø (mm)	t (mm)	PART NUMBER
343	45	25.4	6.35	<a href="#">FLM-343-1025-45</a>
515	45	25.4	6.35	<a href="#">FLM-515-1025-45</a>
1030	45	12.7	6.35	<a href="#">FLM-1030-0525-45</a>
1030	0	25.4	6.35	<a href="#">FLM-1030-1025-0</a>
1030	45	25.4	6.35	<a href="#">FLM-1030-1025-45</a>
1030	0	50.8	6.35	<a href="#">FLM-1030-2037-0</a>
1030	45	50.8	6.35	<a href="#">FLM-1030-2037-45</a>
1064	0	12.7	6.35	<a href="#">FLM-1064-0525-0</a>
1064	45	12.7	6.35	<a href="#">FLM-1064-0525-45</a>
1064	0	25.4	6.35	<a href="#">FLM-1064-1025-0</a>
1064	45	25.4	6.35	<a href="#">FLM-1064-1025-45</a>
1064	0	50.8	6.35	<a href="#">FLM-1064-2037-0</a>
1064	45	50.8	6.35	<a href="#">FLM-1064-2037-45</a>
1070	45	12.7	6.35	<a href="#">FLM-1070-0525-45</a>
1070	0	25.4	6.35	<a href="#">FLM-1070-1025-0</a>
1070	45	25.4	6.35	<a href="#">FLM-1070-1025-45</a>
1070	0	50.8	6.35	<a href="#">FLM-1070-2037-0</a>
1070	45	50.8	6.35	<a href="#">FLM-1070-2037-45</a>
1550	0	25.4	6.35	<a href="#">FLM-1550-1025-0</a>
1550	45	25.4	6.35	<a href="#">FLM-1550-1025-45</a>

# Nd:YAG 1064/532nm DUAL WAVELENGTH MIRRORS: HM



HM dielectric wavelength mirrors are designed for high reflectivity and durability at both Nd:YAG and doubled Nd:YAG wavelengths at either 0° or 45°.

- ▶ R > 99.0% at 1064nm and 532nm
- ▶ Incidence angles other than 0° and 45° may be specified
- ▶ Other substrate dimensions are available for OEM capabilities

## Specifications

Product Code: **HM**

**Substrate Material:**

Standard Grade Corning 7980 1-D (Fused Silica)

**Diameter Tolerance:** +0/-0.25mm

**Thickness Tolerance:** ±0.25mm

**Wedge:** ≤ 5 arc minutes

**Chamfer:** 0.35mm leg width at 45° nominal

**S1 Surface Figure:** < λ/10 p-v at 633nm before coating; after coating on select substrates

**S1 Surface Quality:** 10-5 scratch-dig per MIL-PRF-13830b (at 100W)

**S2 Surface Quality:** Commercial polish

**Clear Aperture:** ≥ 85% of central diameter

**Angle of Incidence:** 0° or 45° options

**Adhesion and Durability:** Per MIL-C-48497a

**Reflectance:**

R ≥ 99.0% at 0° at 1064nm and 532nm

R ≥ 98.5% at 45°, P-Pol at 1064nm and 532nm

**Damage Threshold:**

8 J/cm<sup>2</sup>, 20ns, 20Hz at 1064nm

3 J/cm<sup>2</sup>, 10ns, 20Hz at 532nm

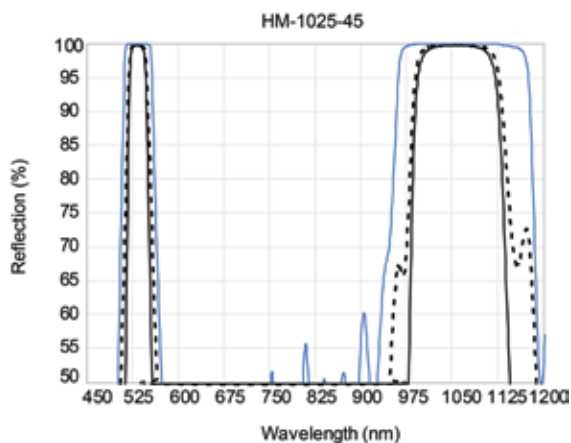
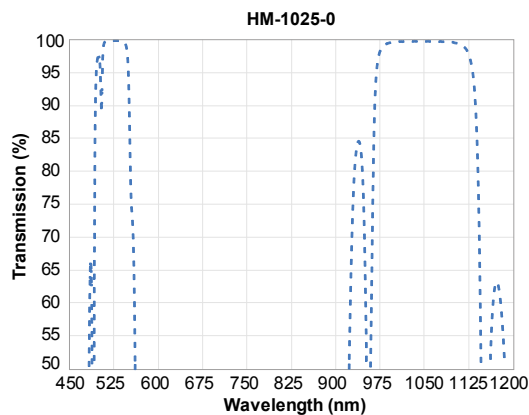

P-POL: — UNP: - - - - S-POL: — 0°: ·····

Nd:YAG 1064/532nm DUAL WAVELENGTH MIRRORS				
Wavelength (nm)	Incidence Angle	Ø (mm)	t (mm)	PART NUMBER
1064/532	0°	12.7	6.35	HM-0525-0
1064/532	45°	12.7	6.35	HM-0525-45
1064/532	0°	25.4	6.35	HM-1025-0
1064/532	45°	25.4	6.35	HM-1025-45
1064/532	0°	50.8	9.5	HM-2037-0
1064/532	45°	50.8	9.5	HM-2037-45

## Nd:YAG 1064/633nm DUAL WAVELENGTH MIRRORS: YH



YH dielectric wavelength mirrors are designed for high reflectivity and durability at both Nd:YAG and HeNe wavelengths at either 0° or 45°.

- ▶ R > 99% at 1064nm and R > 80% at 633nm
- ▶ Alignment mirror for Nd:YAG using HeNe laser
- ▶ Contact an applications engineer for OEM options

### Specifications

Product Code: **YH**

**Substrate Material:**

Standard Grade Corning 7980 1-D (Fused Silica)

**Diameter Tolerance:** +0/-0.25mm

**Thickness Tolerance:** ±0.25mm

**Wedge:** ≤ 5 arc minutes

**Chamfer:** 0.35mm leg width at 45° nominal

**S1 Surface Figure:** < λ/10 p-v at 633nm before coating; after coating on select substrates

**S1 Surface Quality:** 10-5 scratch-dig per MIL-PRF-13830b

**S2 Surface Quality:** Commercial polish

**Clear Aperture:** ≥ 85% of central diameter

**Angle of Incidence:** 45° only

**Adhesion and Durability:** Per MIL-C-48497a

**Reflectance:**

R ≥ 99% at 1064nm, R ≥ 80% at 633nm, at 45° UNP

**Damage Threshold:** >8 J/cm<sup>2</sup>, 20ns, 20Hz at 1064nm

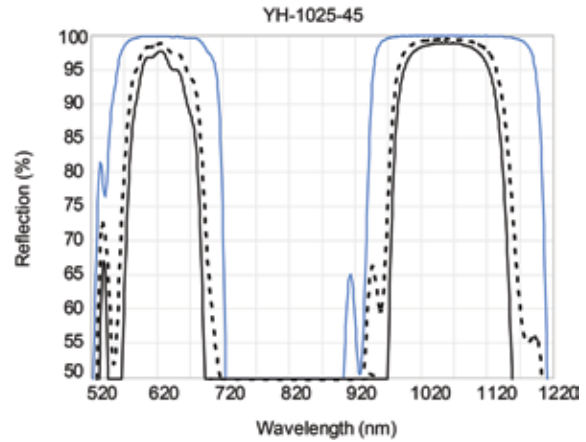

P-POL: — UNP: - - - - S-POL: — 0°: ·····

ND:YAG 1064/633nm DUAL WAVELENGTH MIRROR				
Wavelength (nm)	Incidence Angle	Ø (mm)	t (mm)	PART NUMBER
1064/633	45°	25.4	6.35	YH-1025-45
1064/633	45°	50.8	9.5	YH-2037-45

# HIGH POWER TI:SAPPHIRE ULTRAFAST MIRRORS: TLMB



These mirrors are available upon special request for all Ti:Sapphire laser-related center wavelengths.

- ▶ Designed for Pulse Lengths > 30 fs
- ▶ Broadband design with ultralow group velocity dispersion (GVD)
- ▶ High reflectivity: 740 – 860nm for 0° or 45° Unpolarized

Product Code: **TLMB**

Substrate Material: N-BK7

Diameter Tolerance: +0/-0.25mm

Thickness Tolerance: ±0.25mm

Wedge: ≤ 5 arc minutes

Chamfer:

Ø ≤ 50.8mm: 0.35mm leg width at 45° nominal

Ø > 50.8mm: 0.85mm leg width at 45° nominal

S1 Surface Figure: < λ/10 p-v at 633nm (after coating)

S1 Surface Quality: 10-5 scratch-dig per MIL-PRF-13830b (at 100W)

S2 Surface Quality: Commercial polish

Clear Aperture: ≥ 85% of central diameter

Angle of Incidence: 0° or 45° options

Center Wavelength: 800nm

Reflectance: R > 99.0% from 740 – 860nm for 0° or 45° UNP

Adhesion and Durability: Per MIL-C-48497a, Insoluble in lab solvents.

Damage Threshold:

Pulsed: 0.46 J/cm<sup>2</sup>, 50 fsec, 50Hz at 800nm

## BUILD YOUR PART NUMBER

STEP-1	STEP-2	STEP-3	STEP-4
PRODUCT CODE	WAVELENGTH	ANGLE OF INCIDENCE	SIZE CODE
TLMB	800	45	1025

EXAMPLE: TLMB-800-45-1025

## CHOOSE FROM THE OPTIONS BELOW.

### 1. PRODUCT CODE

TLMB

### 2. WAVELENGTH (nm)

800

### 3. ANGLE OF INCIDENCE in Degrees

0	0 degrees (normal incidence)
45	45 degrees

### 4. SIZE CODE

	DIAMETER (mm)	THICKNESS (mm)
2506M	25.0	6.0
1025	25.4	6.35
5010M*	50.0	10.0
2037	50.8	9.53
3050*	76.2	12.7
4050*	101.6	12.7

\* Only available at 45° AOI

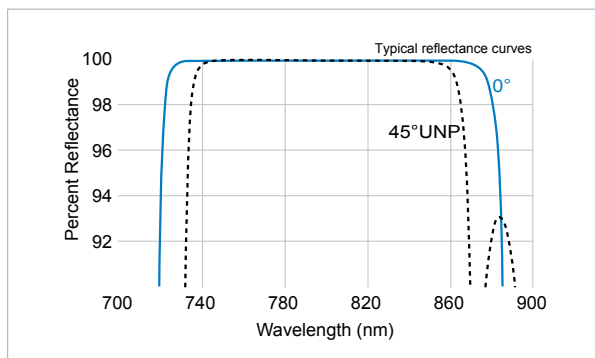

TLMB-800 Ti:Sapphire broadband mirror showing 0° and 45° angle of incidence designs

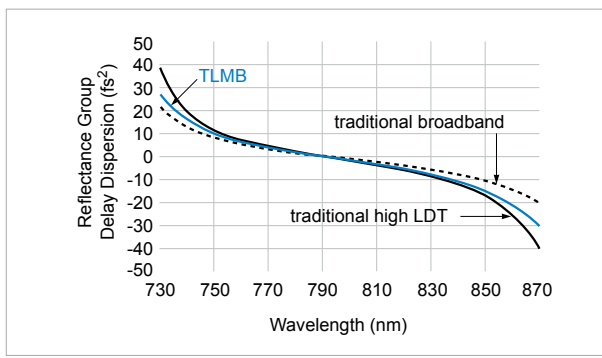

A comparison of group delay dispersion vs wavelength of traditional broadband, traditional high laser damage threshold, and the CVI Laser Optics TLMB ultrafast mirror

## TUNABLE BROADBAND MIRRORS: TLM2



### Specifications

Product Code: **TLM2**

Substrate Material: N-BK7

Diameter Tolerance: +0/-0.25mm

Thickness Tolerance: ±0.25mm

Wedge: ≤ 5 arc minutes

Chamfer: 0.35mm leg width at 45° nominal

Concentricity: ≤ 0.05mm (spherical substrates only)

Radius Tolerance: ±0.5% (spherical substrates only)

S1 Surface Figure: <math>\lambda/10</math> p-v at 633nm before coating; after coating on select substrates

S1 Surface Quality: 10-5 scratch-dig per MIL-PRF-13830b (at 100W)

S2 Surface Quality: Commercial polish

Adhesion and Durability: Per MIL-C-48497a

Clear Aperture: ≥ 85% of central diameter

Center Wavelength: 800nm, or 1030nm

Reflectance: Please refer to the typical bandwidth tables

Angle of Incidence: 45° only

Damage Threshold:

Pulsed:

0.28 J/cm<sup>2</sup>, 50 fsec, 50Hz at 800nm

0.50 J/cm<sup>2</sup>, 20ns, 20Hz at 1064nm

Center Wavelength Tolerance: ±3%

Designed for Pulse Lengths: > 30 fs

#### TYPICAL BANDWIDTH FOR TLM2 MIRRORS

Center Wave-length (nm)	R > 99% 0°	R > 99.5% S	R > 99% 45° P
800	156	197	76
1030	180	230	80

The TLM2 mirrors are specially designed to achieve high reflectivity and low dispersion for cw oscillators and low-fluence pulses. These mirrors can be coated for any angle of incidence from 0° to 60° and any center wavelength between 450nm and 2100nm for OEM applications. For 45° tuning mirror applications involving very short pulses or very broad bandwidths. Using s - polarization minimizes pulse distortion and maximizes average reflectivity.

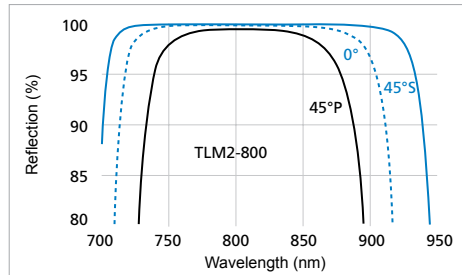

Reflectivity vs wavelength of TLM2-800 broadband laser mirror showing 0° and 45° angle of incidence designs

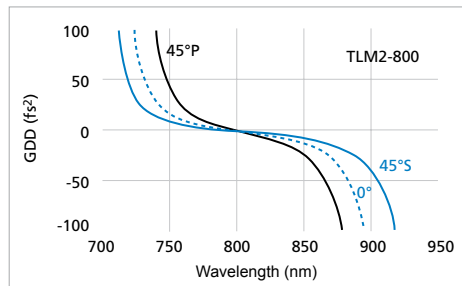

Group delay dispersion vs wavelength of TLM2-800 broadband laser mirror showing 0° and 45° angle of incidence designs

### BUILD YOUR PART NUMBER

STEP-1	STEP-2	STEP-3	STEP-4
PRODUCT CODE	WAVELENGTH	ANGLE OF INCIDENCE	SIZE CODE
TLM2	800	45	1025

EXAMPLE: TLM2-800-45-1025

### CHOOSE FROM THE OPTIONS BELOW.

#### 1. PRODUCT CODE

TLM2

#### 2. WAVELENGTH (nm)

800

1030

#### 3. ANGLE OF INCIDENCE in Degrees

45

45 degrees

#### 4. SIZE CODE

0525

DIAMETER (mm)

12.7

THICKNESS (mm)

6.35

1025

25.4

6.35



# FLAT MIRRORS WITH MAXBRITe™ BROADBAND COATINGS: MPQ



## Specifications

Product Code: **MPQ**

- Material:**  
Standard Grade Corning 7980 1-D (Fused Silica)
- Diameter Tolerance:** +0/-0.15mm
- Thickness Tolerance:** ±0.25mm
- Parallelism:** ≤ 3 arc minutes
- Chamfer:** 0.35mm leg width at 45° nominal
- S1 Surface Flatness:** <math>\lambda/4</math> p-v at 633nm before coating
- S1 Surface Quality:** 60-40 scratch-dig per MIL-PRF-13830b
- Clear Aperture:** ≥ 90% of edge dimension or diameter
- Average Reflectance:** ≥ 98% at 0° – 45° UNP
- Damage Threshold:** 0.4 J/cm<sup>2</sup>, 10ns at 532 (typical)

MAXBRITe™ coatings offer extremely high reflectance over a broad range of wavelengths. Most of the ultraviolet and visible laser wavelengths are covered by one of the two MAXBRITe coating ranges.

- ▶ MAXBRITe coatings operate for angles of incidence as high as 45°.
- ▶ Minimum of 98% reflectance is achieved over a wide wavelength range at angles of incidence from 0 to 45°.
- ▶ Contact CVI Laser Optics for OEM options.

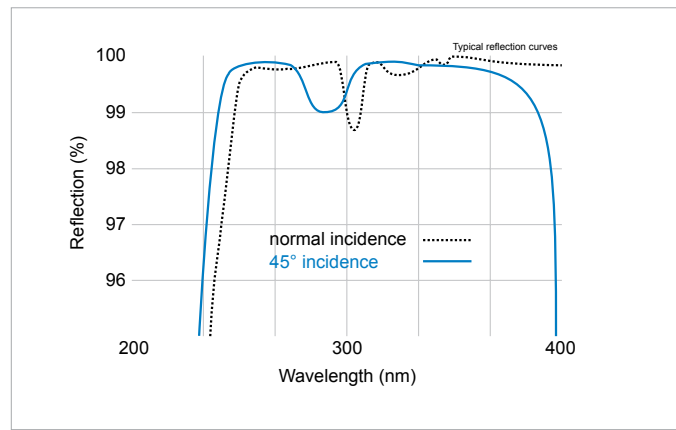

MAXBRITe™ coating 245 – 390nm

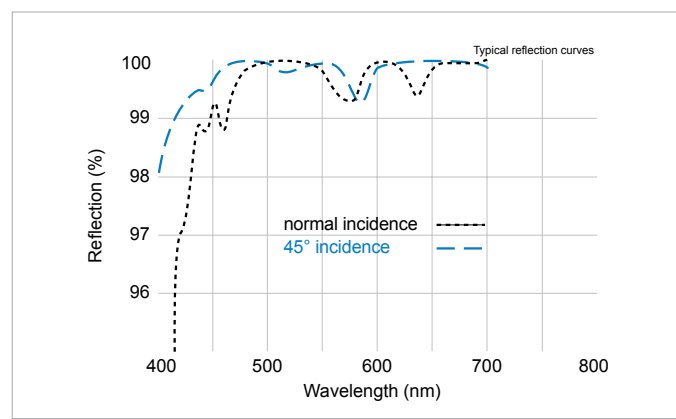

MAXBRITe™ coating 420 – 700nm

FLAT MIRRORS WITH MAXBRITe™ BROADBAND COATINGS			
UV Broadband Mirror, Round 245 - 390nm			
Ø (mm)	t (mm)	Clear Aperture (mm)	PART NUMBER
25.0	6.0	22.5	<b>MPQ-245-390-2506M</b>
Visible Broadband Mirror, Round 420 - 700nm			
25.0	6.0	22.5	<b>MPQ-420-700-2506M</b>

## VACUUM UV ALUMINUM MIRRORS: VUVA



### Specifications

Product Code: **VUVA**

**Substrate Material:**

Standard Grade Corning 7980 1-D (Fused Silica)

**Diameter Tolerance:** +0/-0.25mm

**Thickness Tolerance:** ±0.25mm

**Wedge:** ≤ 5 arc minutes

**Chamfer:** 0.35mm leg width at 45° nominal

**S1 Surface Figure:** <  $\lambda/10$  p-v at 633nm

**S1 Surface Quality:** 40-20 scratch-dig per MIL-PRF-13830b

**S2 Surface Quality:** Commercial polish

**Clear Aperture:** ≥ 85% of central diameter

**Adhesion and Durability:** Per MIL-M-13508c

**Reflectance:** R > 85% at 157nm by design

Based on CVI Laser Optics high density aluminum coating technology, VUVA mirrors are designed for optimized performance at 157nm. Certification of performance at wavelength is available for an additional charge. Call us for more details.

► Contact an applications engineer for OEM capabilities

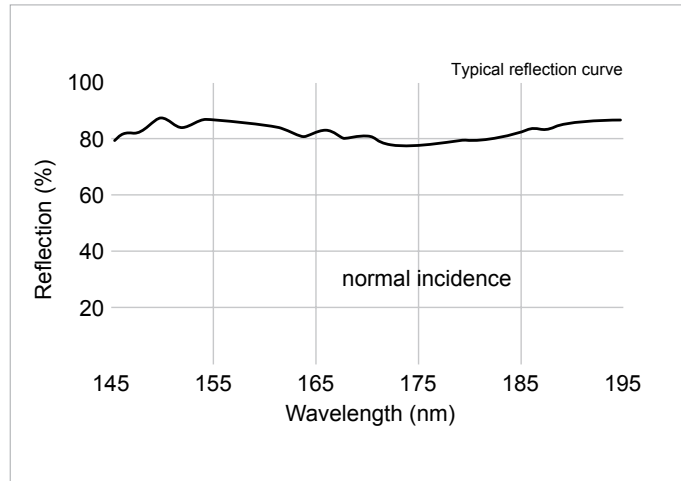

Theoretical design of VUVA coating at 157nm and 0°

VACUUM UV ALUMINUM MIRRORS		
Ø (mm)	t (mm)	PART NUMBER
25.4	6.35	VUVA-PM-1025-UV
50.8	9.53	VUVA-PM-2037-UV

## DEEP UV ALUMINUM MIRRORS: DUVA

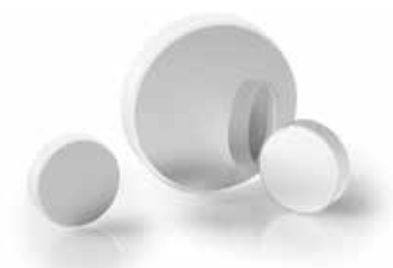

Based on CVI Laser Optics high-density aluminum coating technology, broadband DUVA mirrors provide significantly higher 193nm reflectance and durability than standard UV-protected aluminum mirrors. Choose semi-custom or standard optics for your ellipsometry, spectroscopy, and semiconductor lithography or metrology applications.

► Contact an applications engineer for OEM capabilities

### Specifications

Product Code: **DUVA**

**Substrate Material:**

Standard Grade Corning 7980 1-D (Fused Silica)

**Diameter Tolerance:** +0/-0.25mm

**Thickness Tolerance:** ±0.25mm

**Wedge:** ≤ 5 arc minutes

**Chamfer:** 0.35mm leg width at 45° nominal

**S1 Surface Figure:** < λ/10 p-v at 633nm

**S1 Surface Quality:** 40-20 scratch-dig per MIL-PRF-13830b

**S2 Surface Quality:** Commercial polish

**Clear Aperture:** ≥ 85% of central diameter

**Adhesion and Durability:** Per MIL-M-13508c

**Reflectance:**

R > 90% at 193nm, R<sub>avg</sub> ≥ 85% at 400 – 1200nm

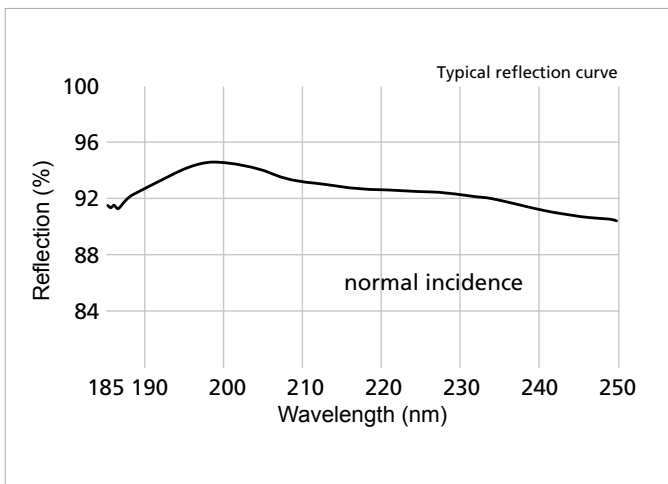

Reflection vs wavelength of 193nm deep UV aluminum coating at 0°

DEEP UV ALUMINUM MIRRORS		
Ø (mm)	t (mm)	PART NUMBER
12.7	3.18	DUVA-PM-0512-UV
25.4	6.35	DUVA-PM-1025-UV
50.8	9.53	DUVA-PM-2037-UV

## UV ENHANCED ALUMINUM FLAT MIRRORS: PAUV



UV enhanced aluminum mirrors have an additional dielectric coating that prevents oxidation and preserves the reflectance of bare aluminum in the ultraviolet.

- ▶ Average reflectance is greater than 86% from 250 to 600nm
- ▶ Contact an applications engineer for OEM capabilities

### Specifications

Product Code: **PAUV**

Substrate Material: N-BK7

Dimensional Tolerances:

Square: +0/-0.25mm

Round: +0/-0.25mm

Thickness Tolerance: ±0.25mm

Parallelism: ≤ 5 arc minutes

Chamfer:

Ø ≤ 50.8mm: 0.35mm leg width at 45° nominal

Ø > 50.8mm: 0.85mm leg width at 45° nominal

**S1 Surface Figure:** < λ/10 p-v at 633nm on select substrates (see table)

**S1 Surface Quality:** 40-20 scratch-dig per MIL-PRF-13830b

**S2 Surface Quality:** Commercial polish

**Clear Aperture:** 90% of edge dimension or diameter (85% for PAUV-PM series)

**Coating:** UV-enhanced aluminum

**Average Reflectance:** ≥ 85% at 250 – 600nm

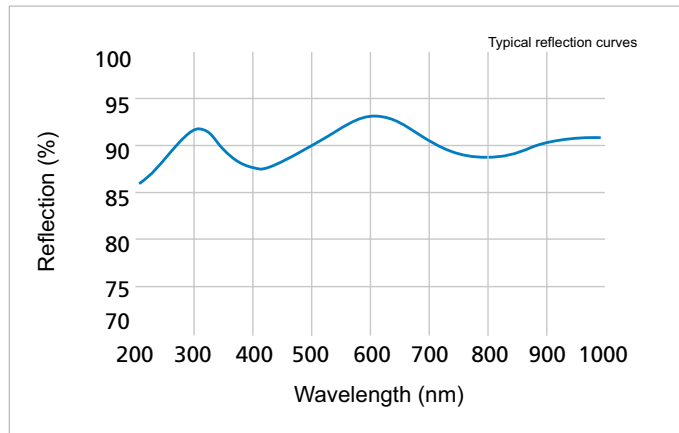

UV enhanced aluminum coating at 0°

UV ENHANCED ALUMINUM FLAT MIRRORS						
Shape	Ø (mm)	□ (mm)	t (mm)	Clear Aperture (mm)	Surface Figure (S1)	PART NUMBER
Round	12.7	—	6.35	11.3	< λ/10	PAUV-PM-0525-C
Round	25.4	—	6.35	21.6	< λ/10	PAUV-PM-1025-C
Square	—	25.4	6.35	22.5x22.5	< λ/4	PAUV-SQM-1025-C
Round	50.8	—	10.0	45.0	< λ/10	PAUV-PM-2037-C
Square	—	50.8	9.53	45.0x45.0	< λ/4	PAUV-SQM-2037-C
Round	76.2	—	12.7	64.8	< λ/10	PAUV-PM-3050-C

## PROTECTED ALUMINUM FLAT MIRRORS: PAV



### Specifications

Product Code: **PAV**

Substrate Material: N-BK7

Dimensional Tolerances:

Square: +0/-0.25mm

Round: +0/-0.25mm

Thickness Tolerance: ±0.25mm

Parallelism: ≤ 5 arc minutes

Chamfer:

Ø ≤ 50.8mm: 0.35mm leg width at 45° nominal

Ø > 50.8mm: 0.85mm leg width at 45° nominal

S1 Surface Figure: < λ/10 p-v at 633nm on select substrates

S1 Surface Quality: 40-20 scratch-dig per MIL-PRF-13830b

S2 Surface Quality: Commercial polish

Clear Aperture:

Round: ≥ 85% of central diameter

Square: ≥ 90% of edge dimension

Coating: Protected aluminum

Average Reflectance: ≥ 87% at 400 – 800nm

Protected aluminum is the best general-purpose metallic coating for external reflectors in the visible and near-infrared spectrum.

- ▶ Average reflectance greater than 87% from 400 to 800nm
- ▶ Contact an applications engineer for OEM capabilities

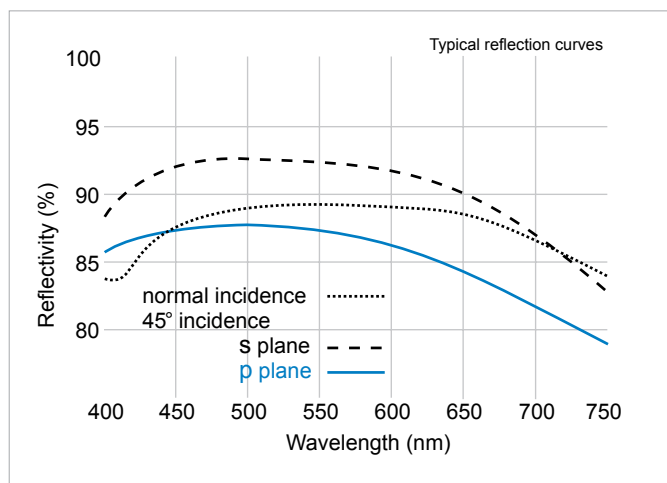

Protected aluminum coating

PROTECTED ALUMINUM FLAT MIRRORS						
Shape	Ø (mm)	□ (mm)	t (mm)	Clear Aperture (mm)	Surface Figure (S1)	PART NUMBER
Round	12.7	—	6.35	10.8	< λ/10	PAV-PM-0525-C
Round	25.4	—	6.35	21.6	< λ/10	PAV-PM-1025-C
Square	—	25.4	6.35	22.5x22.5	< λ/4	PAV-SQM-1025-C
Round	50.8	—	9.53	43.2	< λ/10	PAV-PM-2037-C
Square	—	50.8	9.53	45.0x45.0	< λ/4	PAV-SQM-2037-C
Round	76.2	—	12.7	64.8	< λ/10	PAV-PM-3050-C

## ENHANCED ALUMINUM FLAT MIRRORS: EAV



### Specifications

Product Code: **EAV**

Substrate Material: N-BK7

Diameter: +0/-0.25mm

Thickness Tolerance: ±0.25mm

Parallelism: ≤ 5 arc minutes

Chamfer:

Ø ≤ 50.8mm: 0.35mm leg width at 45° nominal

Ø > 50.8mm: 0.85mm leg width at 45° nominal

S1 Surface Figure: <math>\lambda/10</math> p-v at 633nm

S1 Surface Quality: 40-20 scratch-dig per MIL-PRF-13830b

S2 Surface Quality: Commercial polish

Clear Aperture: ≥ 85% of central diameter

Coating: Enhanced aluminum

Average Reflectance: ≥ 92% at 450–650nm

Enhanced aluminum is an aluminum coating overcoated with a durable multi-layer dielectric film which both increases reflectance throughout the visible spectrum and provides protection from the environment and handling.

- ▶ Peak reflectance is 95% with average reflectance across the visible spectrum of 92%

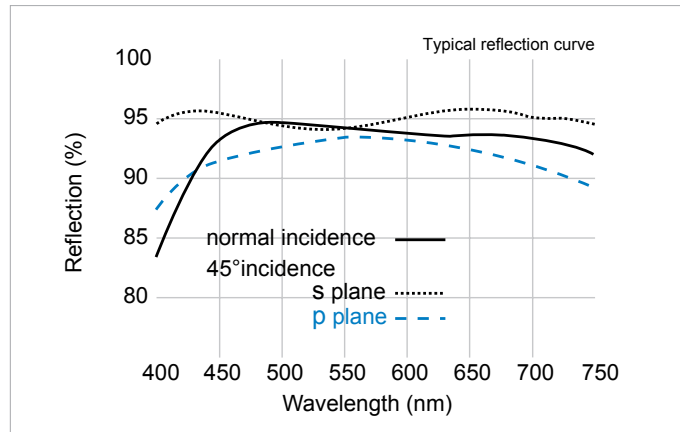

Enhanced aluminum coating

ENHANCED ALUMINUM FLAT MIRRORS			
Ø (mm)	t (mm)	Clear Aperture (mm)	PART NUMBER
12.7	6.35	11.3	EAV-PM-0525-C
25.4	6.35	22.5	EAV-PM-1025-C
50.8	9.53	45.0	EAV-PM-2037-C
76.2	12.7	67.5	EAV-PM-3050-C

## PROTECTED SILVER FLAT MIRRORS: PS

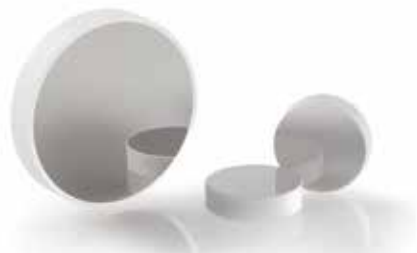

- ▶ Protected silver has higher reflectance than aluminum throughout the visible and near-infrared spectral region
- ▶ Minimal pulse distortion for ultrafast Ti:Sapphire lasers
- ▶ A proprietary overcoat provides increased durability
- ▶ CVI Laser Optics suggests using the drag and drop method with acetone for the cleaning of these mirrors.
- ▶ Contact an applications engineer for OEM capabilities

### Specifications

Product Code: **PS**

Substrate Material: N-BK7

Dimensional Tolerances:

Square: +0/-0.25mm

Round: +0/-0.25mm

Thickness Tolerance: ±0.25mm

Parallelism: ≤ 5 arc minutes

Chamfer:

Ø ≤ 50.8mm: 0.35mm leg width at 45° nominal

Ø > 50.8mm: 0.85mm leg width at 45° nominal

S1 Surface Figure: < λ/10 p-v at 633nm on select substrates

S1 Surface Quality: 40-20 scratch-dig per MIL-PRF-13830b

S2 Surface Quality: Commercial polish

Clear Aperture:

Round: ≥ 85% of central diameter

Square: ≥ 80% of edge dimension

Coating: Protected silver

Average Reflectance: ≥ 95% at 400nm to 20μm

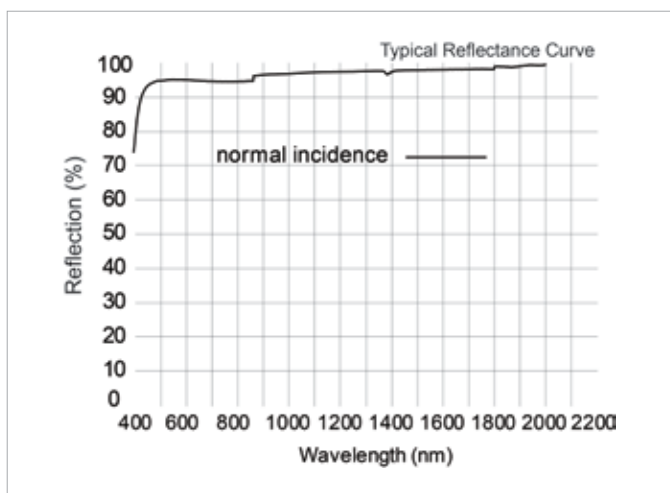

Protected silver coating at 0°

PROTECTED SILVER FLAT MIRRORS						
Shape	Ø (mm)	□ (mm)	t (mm)	Min. Clear Aperture (mm)	Surface Figure (S1)	PART NUMBER
Round	12.7	—	6.35	10.8	< λ/10	PS-PM-0525-C
Round	25.4	—	6.35	21.6	< λ/10	PS-PM-1025-C
Square	—	25.4	6.35	22.5x22.5	< λ/4	PS-SQM-1025-C
Round	50.8	—	9.53	43.2	< λ/10	PS-PM-2037-C
Square	—	50.8	9.53	45.0x45.0	< λ/4	PS-SQM-2037-C
Round	76.2	—	12.7	64.8	< λ/10	PS-PM-3050-C

## PROTECTED GOLD FLAT MIRRORS: PG

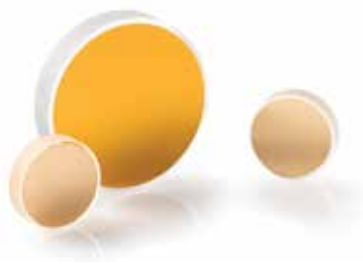

- ▶ Protected gold combines the natural spectral performance of gold with the enhanced protection of a durable dielectric overcoat
- ▶ Protected gold provides 95.5% average reflectance from 650 to 1700nm, and over 98% average reflectance from 2 to 20 μm
- ▶ Contact an applications engineer for OEM capabilities and/or bare gold coatings

### Specifications

Product Code: **PG**

Substrate Material: N-BK7

Dimensional Tolerances:

Square: +0/-0.25mm

Round: +0/-0.25mm

Thickness Tolerance: ±0.25mm

Parallelism: ≤ 5 arc minutes

Chamfer:

Ø ≤ 50.8mm: 0.35mm leg width at 45° nominal

Ø > 50.8mm: 0.85mm leg width at 45° nominal

S1 Surface Figure: < λ/10 p-v at 633nm on select substrates

S1 Surface Quality: 40-20 scratch-dig per MIL-PRF-13830b

S2 Surface Quality: Commercial polish

Clear Aperture:

Square: ≥ 80% of edge dimension

Round: ≥ 85% of central diameter

Coating: Protected gold

Average Reflectance: ≥ 95.5% at 650 – 1700nm, ≥ 98.0% at 2 – 20μm

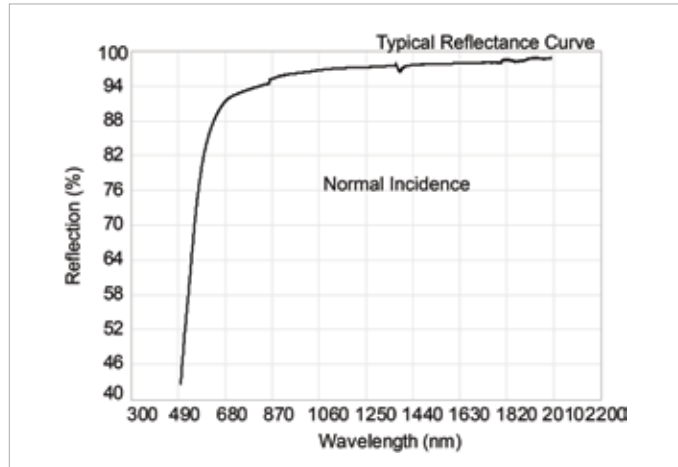

Protected gold coating at 0°

### PROTECTED GOLD FLAT MIRRORS

Shape	Ø (mm)	□ (mm)	t (mm)	Clear Aperture (mm)	Surface Figure (S1)	PART NUMBER
Round	12.7	—	6.35	10.8	< λ/10	PG-PM-0525-C
Round	25.4	—	6.35	21.6	< λ/10	PG-PM-1025-C
Round	50.8	—	9.53	43.2	< λ/10	PG-PM-2037-C
Round	76.2	—	12.7	64.8	< λ/10	PG-PM-3050-C



## CONVEX SPHERICAL FUSED SILICA MIRROR BLANKS: SMCX-UV



The fused silica plano-convex mirror substrates are polished to a 10-5,  $\lambda/10$  surface on both sides, so they can be used as high reflectors, dichroic mirrors, or partial reflecting output couplers.

- ▶ All CVI Laser Optics high reflector, metal, and partial reflector coatings available
- ▶ Mirror focal length =  $-r/2$
- ▶ Other dimensions and radii available in prototype and production quantities
- ▶ Tighter radius tolerance available

### Specifications

Product Code: **SMCX-UV**

**Substrate Material:**

Standard Grade Corning 7980 1-D (Fused Silica)

**Diameter Tolerance:** +0/-0.25mm

**Thickness Tolerance:**  $\pm 0.25$ mm

**Chamfer:** 0.35mm leg width at 45° nominal

**Concentricity:** < 0.05mm

**Radius Tolerance:**  $\pm 0.5\%$

**S1 Surface Figure:** <  $\lambda/10$  p-v at 633nm

**S1 Surface Quality:** 10-5 scratch-dig per MIL-PRF-13830b (at 100W)

**S2 Surface Figure:** <  $\lambda/10$  p-v at 633nm

**S2 Surface Quality:** 10-5 scratch-dig per MIL-PRF-13830b (at 100W)

**Clear Aperture:**  $\geq 85\%$  of central diameter

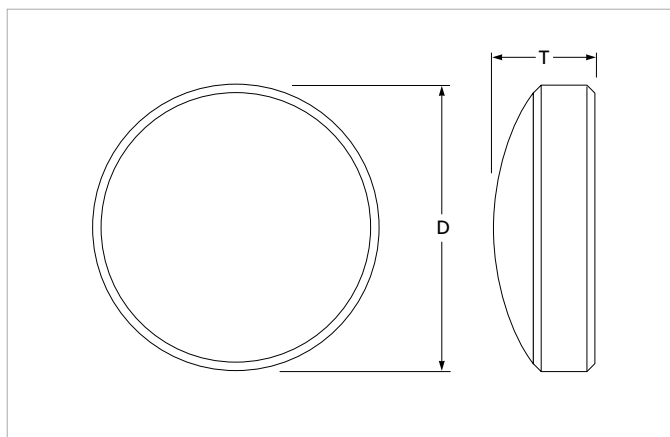

Convex spherical mirror blank

CONVEX FUSED SILICA SPHERICAL MIRROR BLANKS			
$\varnothing$ (mm)	t (mm)	r (m)	PART NUMBER
12.7	6.35	1.00	<a href="#">SMCX-0525-1.00-UV</a>
25.4	6.35	0.30	<a href="#">SMCX-1025-0.30-UV</a>
25.4	6.35	0.50	<a href="#">SMCX-1025-0.50-UV</a>
25.4	6.35	1.00	<a href="#">SMCX-1025-1.00-UV</a>

CONCAVE SPHERICAL FUSED SILICA / N-BK7 MIRROR BLANKS: SMCC-C, SMCC-UV



Specifications

Product Code: **SMCC-C, SMCC-UV**

Substrate Material: N-BK7 or Standard Grade Corning 7980 1-D (Fused Silica)

Diameter Tolerance: +0/-0.25mm

Thickness Tolerance: ±0.25mm

Concentricity: < 0.05mm

Radius Tolerance:

±0.5% for  $r \leq 3.5$  m

±1.0% for  $r > 3.5$  m

S1 Surface Figure:  $< \lambda/10$  p-v at 633nm

S1 Surface Quality: 10-5 scratch-dig per MIL-PRF-13830b (at 100W)

S2 Surface Figure:  $< \lambda/10$  p-v at 633nm

S2 Surface Quality: 10-5 scratch-dig per MIL-PRF-13830b (at 100W)

Clear Aperture:  $\geq 85\%$  of central diameter

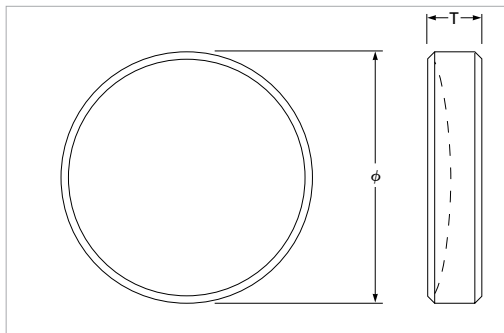

Concave spherical mirror blank

CONCAVE SPHERICAL MIRROR BLANKS:			
Standard Grade Corning 7980 1-D (Fused Silica)			
Ø (mm)	t (mm)	r (m)	PART NUMBER
12.7	6.35	0.025	SMCC-0525-0.025-UV
12.7	6.35	0.050	SMCC-0525-0.050-UV
12.7	6.35	0.075	SMCC-0525-0.075-UV
12.7	6.35	0.10	SMCC-0525-0.10-UV
12.7	6.35	0.15	SMCC-0525-0.15-UV
12.7	6.35	0.20	SMCC-0525-0.20-UV
12.7	6.35	0.25	SMCC-0525-0.25-UV
12.7	6.35	0.50	SMCC-0525-0.50-UV
12.7	6.35	1.00	SMCC-0525-1.00-UV
12.7	6.35	1.50	SMCC-0525-1.50-UV
12.7	6.35	5.00	SMCC-0525-5.00-UV
25.4	6.35	0.025	SMCC-1025-0.025-UV
25.4	6.35	0.050	SMCC-1025-0.050-UV
25.4	6.35	0.10	SMCC-1025-0.10-UV
25.4	6.35	0.15	SMCC-1025-0.15-UV
25.4	6.35	0.20	SMCC-1025-0.20-UV
25.4	6.35	0.25	SMCC-1025-0.25-UV
25.4	6.35	0.30	SMCC-1025-0.30-UV
25.4	6.35	0.50	SMCC-1025-0.50-UV
25.4	6.35	0.75	SMCC-1025-0.75-UV
25.4	6.35	1.00	SMCC-1025-1.00-UV
25.4	6.35	1.50	SMCC-1025-1.50-UV
25.4	6.35	2.00	SMCC-1025-2.00-UV
25.4	6.35	3.00	SMCC-1025-3.00-UV
25.4	6.35	5.00	SMCC-1025-5.00-UV
25.4	6.35	10.0	SMCC-1025-10.0-UV
50.8	9.53	0.50	SMCC-2037-0.50-UV
50.8	9.53	1.00	SMCC-2037-1.00-UV
50.8	9.53	1.50	SMCC-2037-1.50-UV
50.8	9.53	2.00	SMCC-2037-2.00-UV
N-BK7			
Ø (mm)	t (mm)	r (m)	PART NUMBER
12.7	6.35	0.25	SMCC-0525-0.25-C
12.7	6.35	0.50	SMCC-0525-0.50-C
12.7	6.35	1.00	SMCC-0525-1.00-C
25.4	6.35	0.25	SMCC-1025-0.25-C
25.4	6.35	0.50	SMCC-1025-0.50-C
25.4	6.35	1.00	SMCC-1025-1.00-C

## PLANE ROUND FUSED SILICA / N-BK7 MIRROR BLANKS: PM-UV, PM-C



- ▶ All CVI Laser Optics partial reflectors, high reflectors, dichroics and metal coatings available.
- ▶ Other dimensions or materials available in production and prototype quantities

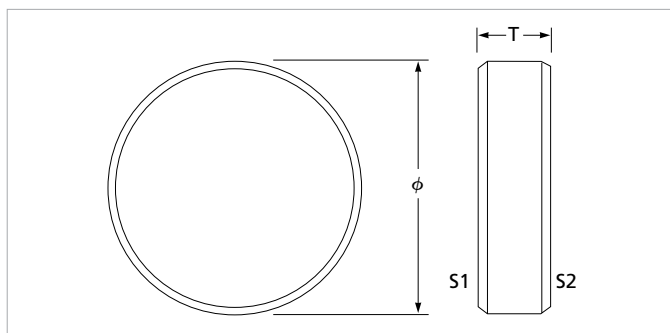

Plane round mirror blank

### Specifications

Product Code: **PM-UV, PM-C**

**Substrate Material:** N-BK7 or  
Standard Grade Corning 7980 1-D (Fused Silica)

**Dimensional Tolerance:** +0/-0.25mm

**Thickness Tolerance:** ±0.25mm

**Wedge:** ≤ 5 arc minutes

**Chamfer:**

Ø ≤ 50.8mm: 0.35mm leg width at 45° nominal

Ø > 50.8mm: 0.85mm leg width at 45° nominal

**S1 Surface Figure:** per table; measured p-v at 633nm

**S1 Surface Quality:** 10-5 scratch-dig  
per MIL-PRF-13830b (at 100W)

**S2 Surface Quality:** Commercial polish

**Clear Aperture:** ≥ 85% of central diameter

#### PLANE ROUND MIRROR BLANKS

Standard Grade Corning 7980 1-D (Fused Silica)

Ø (mm)	t (mm)	S1 Surface Figure	PART NUMBER
12.7	6.35	< λ/10	<a href="#">PM-0525-UV</a>
19.1	6.35	< λ/10	<a href="#">PM-0725-UV</a>
25.0	6.0	< λ/10	<a href="#">PM-2506M-UV</a>
25.4	3.18	< λ/4	<a href="#">PM-1012-UV</a>
25.4	6.35	< λ/10	<a href="#">PM-1025-UV</a>
25.4	9.53	< λ/10	<a href="#">PM-1037-UV</a>
38.1	6.35	< λ/10	<a href="#">PM-1525-UV</a>
50.0	10.0	< λ/10	<a href="#">PM-5010M-UV</a>
50.8	6.35	< λ/10	<a href="#">PM-2025-UV</a>
50.8	9.53	< λ/10	<a href="#">PM-2037-UV</a>
76.2	12.7	< λ/10	<a href="#">PM-3050-UV</a>
101.6	9.53	< λ/10	<a href="#">PM-4037-UV</a>
101.6	12.7	< λ/10	<a href="#">PM-4050-UV</a>
152.4	25.4	< λ/10	<a href="#">PM-6010-UV</a>
N-BK7			
Ø (mm)	t (mm)	S1 Surface Figure	PART NUMBER
12.7	3.18	< λ/10	<a href="#">PM-0512-C</a>
12.7	6.35	< λ/10	<a href="#">PM-0525-C</a>
25.0	6.0	< λ/10	<a href="#">PM-2506M-C</a>
25.4	3.18	< λ/4	<a href="#">PM-1012-C</a>
25.4	6.35	< λ/10	<a href="#">PM-1025-C</a>
50.8	6.35	< λ/4	<a href="#">PM-2025-C</a>
76.2	12.7	< λ/10	<a href="#">PM-3050-C</a>

NOTE: See PW1-UV for additional options (page 94)

PLANE SQUARE FUSED SILICA / N-BK7 MIRROR BLANKS: [SQM-C](#), [SQM-UV](#)



- ▶ Available in N-BK7 and Standard Grade Corning 7980 1-D (Fused Silica)
- ▶ All CVI Laser Optics high reflector, partials, dichroics and metal coatings available
- ▶ Other dimensions available in production and prototype quantities

Specifications

Product Code: [SQM-C](#), [SQM-UV](#)

Substrate Material: N-BK7 or Standard Grade Corning 7980 1-D (Fused Silica)

Dimensional Tolerance: +0/-0.25mm

Thickness Tolerance: ±0.25mm

Wedge: ≤ 5 arc minutes

Chamfer: 0.35mm leg width at 45° nominal

S1 Surface Figure: See table (measured p-v at 633nm)

S1 Surface Quality: 10-5 scratch-dig per MIL-PRF-13830b (at 100W)

S2 Surface Quality: Commercial polish

Clear Aperture: ≥ 85% of central diameter

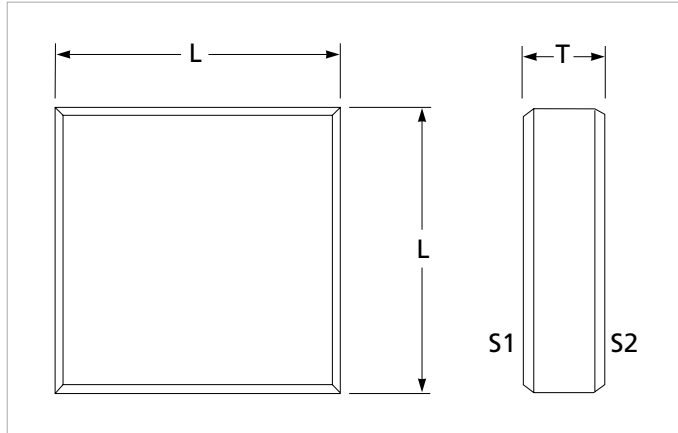

Plane square mirror blank

PLANE SQUARE MIRROR BLANKS			
Standard Grade Corning 7980 1-D (Fused Silica)			
l (mm)	t (mm)	S1 Surface Figure	PART NUMBER
25.4	6.35	< $\lambda/10$	<a href="#">SQM-1025-UV</a>
50.8	9.53	< $\lambda/10$	<a href="#">SQM-2037-UV</a>
N-BK7			
l (mm)	t (mm)	S1 Surface Figure	PART NUMBER
25.4	6.35	< $\lambda/4$	<a href="#">SQM-1025-C</a>
50.8	9.53	< $\lambda/4$	<a href="#">SQM-2037-C</a>

## PLANE RECTANGULAR FUSED SILICA MIRROR BLANKS: RM-UV



### Specifications

Product Code: **RM-UV**

**Substrate Material:**

Standard Grade Corning 7980 1-D (Fused Silica)

**Dimensional Tolerance:** +0/-0.25mm

**Thickness Tolerance:** ±0.25mm

**Wedge:** ≤ 5 arc minutes

**Chamfer:** 0.35mm leg width at 45° nominal

**S1 Surface Figure:** <  $\lambda/4$  p-v at 633nm

**S1 Surface Quality:** 10-5 scratch-dig per MIL-PRF-13830b (at 100W)

**S2 Surface Quality:** Commercial polish

**Clear Aperture:** ≥ 85% of central diameter

- ▶ Available in Standard Grade Corning 7980 1-D (Fused Silica)
- ▶ All CVI Laser Optics high reflector, partials, dichroics and metal coatings available
- ▶ Other dimensions available in production and prototype quantities

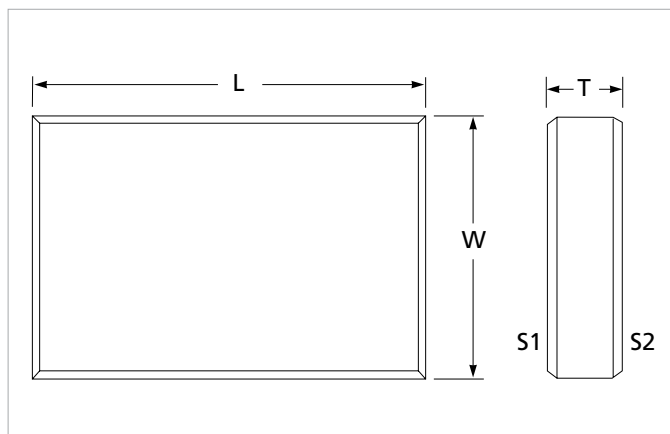

Plane rectangular mirror blank

PLANE RECTANGULAR FUSED SILICA MIRROR BLANKS			
l (mm)	w (mm)	t (mm)	PART NUMBER
20	10	6.35	<b>RM-20.0-10.0-6.35-UV</b>
35	20	9.53	<b>RM-35.0-20.0-9.53-UV</b>
40	25	9.53	<b>RM-40.0-25.0-9.53-UV</b>
50	30	12.7	<b>RM-50.0-30.0-12.7-UV</b>

## Surface Figure: Peak to Valley (PV) vs Root Mean Squared (RMS)

**PV:** The difference between the lowest point and the highest point of the optical surface.

**RMS:** The measurement of the clear aperture of the optical surface, then calculating the standard deviation (taking the square root of all values and squaring them).

- The average PV vs RMS ratio for the combination of: Focus, Astigmatism, Coma and Spherical Aberration, is 3-5:1
- CVI Laser Optics specifies the PV error given the fact that our polishing process is such that our RMS values are significantly below  $\lambda/50$  for our laser grade optics.
- CVI Laser Optics average surface roughness is between  $3\text{-}5\text{\AA}$  for laser grade optics

**Consistent High Quality by a brand you can trust!**

PV:  $< \lambda/20$   
RMS:  $< \lambda/111$   
Laser Grade

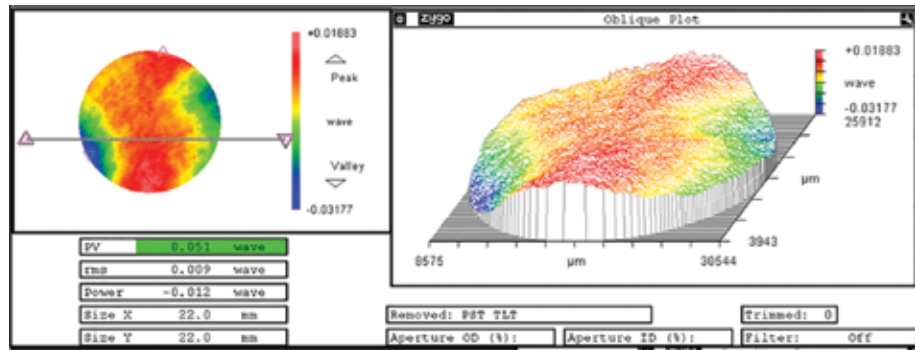

PV:  $< \lambda/10$   
RMS:  $< \lambda/62$   
Laser Grade

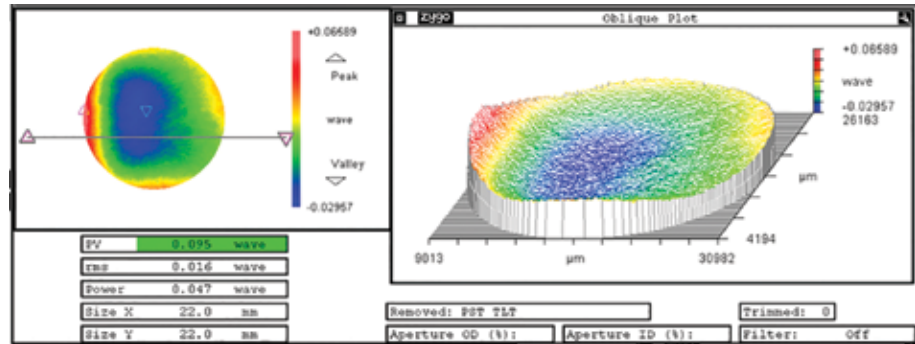

PV:  $< \lambda/4$   
RMS:  $< \lambda/22$   
Image Grade

