



OEM BBO Pockels Cell Kit for Q-switching

System wiring

QKB-01

CONTENTS

CHAPTER 1	COMPONENTS OF THE SYSTEM	1
CHAPTER 2	LAYOUTS OF DEVICES	2
CHAPTER 3	STRUCTURE DIAGRAM	3
CHAPTER 4	QUICK START & STOP GUIDE	3

LIST OF FIGURES

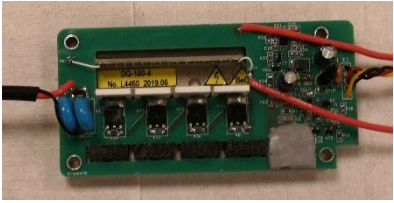

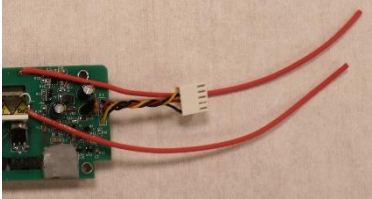



FIGURE 1. TOP VIEW OF THE (HV) POWER SUPPLY	2
FIGURE 2. TOP VIEW OF THE (HV) DRIVER	2
FIGURE 3. STRUCTURE DIAGRAM	3
FIGURE 5. STEPS TO START AND STOP THE SYSTEM	3

LIST OF TABLES

TABLE 1. ITEMS INCLUDED IN OEM DKDP POCKELS CELL KIT	1
TABLE 2. CONTROLS AND CONNECTIONS OF THE (HV) POWER SUPPLY	2
TABLE 3. CONTROLS AND CONNECTIONS OF THE (HV) DRIVER	2

Chapter 1 COMPONENTS OF THE SYSTEM

Table 1. Items included in OEM DKDP Pockels Cell Kit

<p>OEM high voltage (HV) driver</p> <p>Model: DQ-100-4</p>	
<p>OEM high voltage (HV) power supply</p> <p>Model: PS-40-3.6</p>	
<p>Pockels cell</p> <p>Model: PCB3S-C-1064</p>	
<p>[HVP] cables (red, soldered to driver)</p> <p>OEM high voltage driver ↔ Pockels cell</p>	
<p>[HV] cables (soldered to driver)</p> <p>OEM high voltage driver ↔ (HV) power supply</p>	
<p>Synchronization signal cable & +24V cable</p> <p>OEM high voltage driver ↔ Signal generator</p> <p>OEM high voltage driver ↔ Users +24V power supply</p>	
<p>+24V cables</p> <p>Users +24V power supply ↔ (HV) power supply</p>	
<p>USB flash drive</p> <p>Including manuals and technical descriptions</p>	
<p>Mounting stage for Pockels cell</p> <p>Model: PM1</p>	

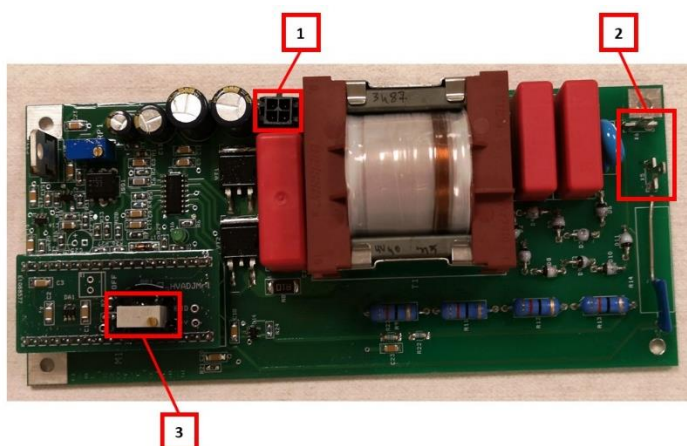

Figure 1. Top view of the (HV) power supply

Table 2. Controls and connections of the (HV) power supply

#	Port
1	Molex 4 (Microsoft series) interface for +24V DC supply
2	Contacts for HV pulse output
3	Internal trimmer for output voltage tuning

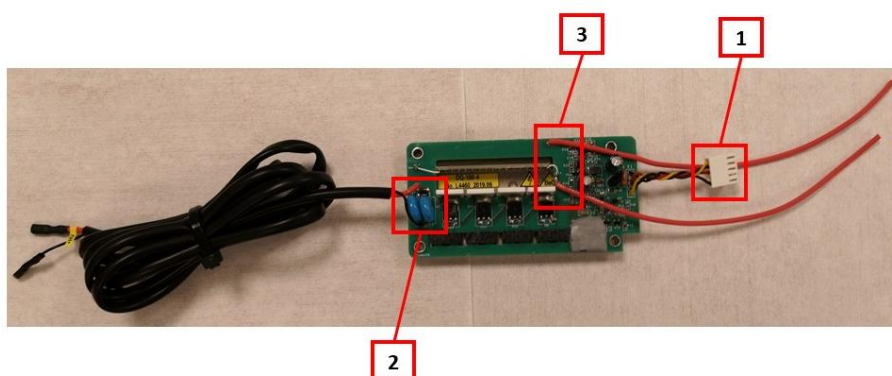

Figure 2. Top view of the (HV) driver

Table 3. Controls and connections of the (HV) driver

#	Port
1	Connector for +24V DC supply and synchronization signal cable
2	Contacts for HV pulse input
3	Output voltage to cell (<5 kV)

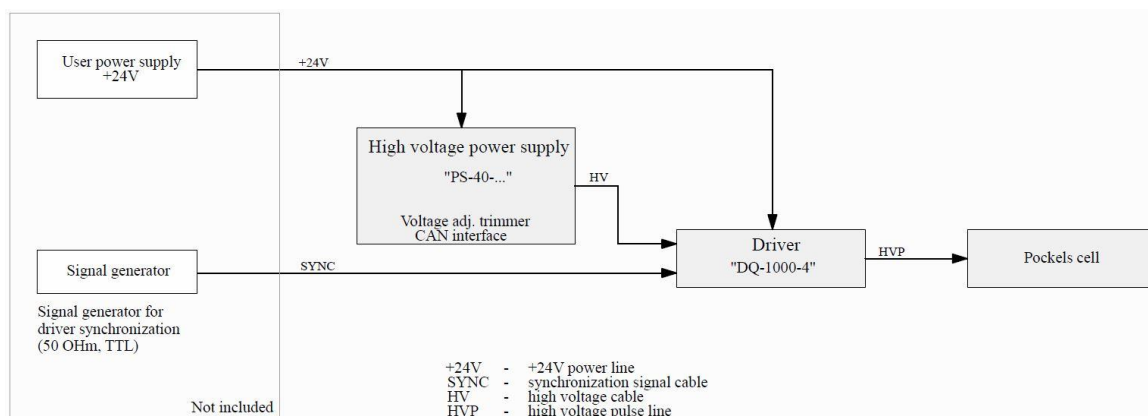

Figure 3. Structure diagram

Warning:

Do not start the device until all cables are connected.

Control signals without High Voltage active may damage the driver

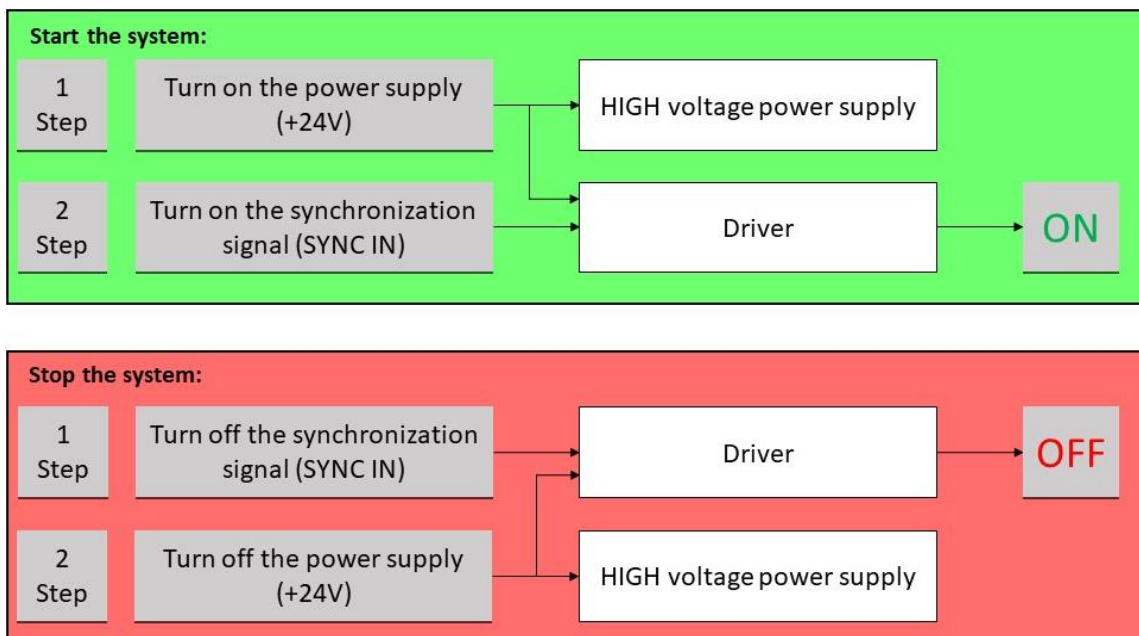

Figure 4. Steps to start and stop the system