



# HIGH VOLTAGE DRIVERS

DP-SP-50-3.6-(Al)-(Option1)

DP-SP-250-3.6-(Al)-(Option1)

DP-SP-250-2.6

DP-SP-500-2.6-(Al)-(Option1)

DP-SP-400-1.5

DP-SP-1000-1.8-(Al)-(Option1)

Technical Description  
Rev. 2202

2022  
Lithuania



# CONTENTS

<b>CHAPTER 1</b>	<b>WARRANTY</b> .....	<b>1</b>
1.1.	WARRANTY STATEMENT .....	1
1.2.	SERVICE CONTACT INFORMATION .....	1
<b>CHAPTER 2</b>	<b>SPECIFICATIONS</b> .....	<b>2</b>
2.1.	GENERAL INFORMATION .....	2
2.1.1.	<i>Models</i> .....	2
2.1.2.	<i>Main Components</i> .....	2
2.2.	TECHNICAL SPECIFICATIONS .....	4
<b>CHAPTER 3</b>	<b>DEVICE LAYOUT</b> .....	<b>6</b>
<b>CHAPTER 4</b>	<b>SAFETY</b> .....	<b>12</b>
<b>CHAPTER 5</b>	<b>IMPORTANT NOTES</b> .....	<b>13</b>
<b>CHAPTER 6</b>	<b>QUICK START GUIDE</b> .....	<b>15</b>
6.1.	SET JUMPER #7 TO REQUIRED OPERATION MODE.....	15
6.2.	SET-UP COOLING .....	15
6.3.	CONNECT WIRES TO THE POCKELS CELL .....	15
6.4.	GROUND THE POCKELS CELL DRIVER TOGETHER WITH THE GENERATOR AND HV SUPPLY .....	16
6.5.	SUPPLY VOLTAGE TO THE DRIVER FROM THE DC POWER SUPPLY .....	16
6.6.	SUPPLY VOLTAGE FROM THE HV SUPPLY.....	16
6.7.	PROVIDE SYNCHRONIZATION PULSES FROM THE GENERATOR.....	16

## LIST OF FIGURES

<b>FIGURE 1.</b> OUTLINE DRAWING AND DIMENSIONS OF THE DRIVER <b>DP-SP-50-3.6</b> .....	6
<b>FIGURE 2.</b> VIEW OF THE DRIVER <b>DP-SP-50-3.6</b> .....	6
<b>FIGURE 3.</b> OUTLINE DRAWING AND DIMENSIONS OF DRIVERS <b>DP-SP-250-3.6, DP-SP-600-2.5, DP-SP-1000-1.8</b> .....	7
<b>FIGURE 4.</b> VIEW OF DRIVERS <b>DP-SP-250-3.6, DP-SP-600-2.5, DP-SP-1000-1.8</b> .....	7
<b>FIGURE 5.</b> OUTLINE DRAWING AND DIMENSIONS OF THE DRIVERS WITH COVER ( <b>-AI-OPTION1</b> ).....	8
<b>FIGURE 6.</b> OUTLINE DRAWING AND DIMENSIONS OF THE DRIVERS WITH COVER ( <b>-AI</b> ) .....	9
<b>FIGURE 7.</b> VIEW OF THE DRIVER WITH COVER ( <b>-AI</b> ) .....	10
<b>FIGURE 8.</b> CONNECTIONS AND CONTROLS ON THE <b>PCB</b> OF THE DRIVER.....	10
<b>FIGURE 9.</b> DRIVER OPERATION CHART .....	13
<b>FIGURE 10.</b> OUTPUT CIRCUIT OF ERROR CONNECTOR .....	14
<b>FIGURE 11.</b> CONTROL TIMING FOR <b>1-INPUT (LEFT) AND 2-INPUT (RIGHT) CONTROLLED DRIVER</b> .....	15
<b>FIGURE 12.</b> INPUT CIRCUIT OF DRIVER.....	17

## LIST OF TABLES

<b>TABLE 1.</b> MODELS .....	2
<b>TABLE 2.</b> MAIN COMPONENTS .....	2
<b>TABLE 3.</b> TECHNICAL SPECIFICATIONS.....	4
<b>TABLE 4.</b> CONNECTION PORTS OF THE DRIVER .....	11

### 1.1. Warranty Statement

---

The Pockels cell drivers are protected by a one-year warranty covering labor and parts. The warranty enters into validity since the shipment date. Any evidence of improper use or unauthorized repair attempts voids the warranty.

### 1.2. Service Contact Information

---

For service/warranty requests, please contact:

EKSMA OPTICS, UAB  
c/o EKSMA Optics, UAB  
Dvarcioniu st. 2B  
LT-10233 Vilnius, Lithuania

Phone: +370 5 272 99 00  
Fax.: +370 5 272 92 99  
E-mail: [info@eksmaoptics.com](mailto:info@eksmaoptics.com)  
Website: [www.eksmaoptics.com](http://www.eksmaoptics.com)

## 2.1. General Information

### 2.1.1. Models

**Table 1. Models**

<i>Model</i>	<i>Description</i>
<b>DP-SP-50-3.6</b>	50kHz repetition rate, 3.6kV output, open PCB, conductive cooling
<b>DP-SP-50-3.6-AI</b>	50kHz repetition rate, 3.6kV output, with cover, water cooling
<b>DP-SP-50-3.6-AI-Option1</b>	50kHz repetition rate, 3.6kV output, with cover, water or conductive cooling
<b>DP-SP-250-2.6</b>	250kHz repetition rate, 2.6kV output, open PCB, water or conductive cooling
<b>DP-SP-250-3.6</b>	250kHz repetition rate, 3.6kV output, open PCB, water or conductive cooling
<b>DP-SP-250-3.6-AI</b>	250kHz repetition rate, 3.6kV output, with cover, water cooling
<b>DP-SP-250-3.6-AI-Option1</b>	250kHz repetition rate, 3.6kV output, with cover, water or conductive cooling
<b>DP-SP-400-1.5</b>	400kHz repetition rate, 1.5kV output, open PCB, water or conductive cooling
<b>DP- SP-500-2.6</b>	500kHz repetition rate, 2.6kV output, open PCB, water or conductive cooling
<b>DP-SP-500-2.6-AI</b>	500kHz repetition rate, 2.6kV output, with cover, water cooling
<b>DP-SP-500-2.6-AI-Option1</b>	500kHz repetition rate, 2.6kV output, with cover, water or conductive cooling
<b>DP-SP-1000-1.8</b>	1000kHz repetition rate, 1.8kV output, open PCB, water or conductive cooling
<b>DP-SP-1000-1.8-AI</b>	1000kHz repetition rate, 1.8kV output, with cover, water cooling
<b>DP-SP-1000-1.8-AI-Option1</b>	1000kHz repetition rate, 1.8kV output, with cover, water or conductive cooling

### 2.1.2. Main Components

**Table 2. Main components**

<i>Component</i>	<i>Quantity</i>	<i>Notes</i>
High voltage (HV) driver <b>DP-SP-*-*</b>	1	-
DC power cable (l=1.5m)	1	-
BNC-SMB cables (l=1.5m)	2	-
HV power supply cable (l=1m)	1	-
Pair of cables for HV output to the Pockels cell (<10 cm)	1	-
Technical description	1	-



## 2.2. Technical Specifications

**Table 3.** Technical specifications

Parameter	Value(s)					
	DP-SP-50-3.6-(AI)-(Option1)	DP-SP-250-3.6-(AI)-(Option1)	DP-SP-250-2.6	DP-SP-500-2.6-(AI)-(Option1)	DP-SP-1000-1.8-(AI)-(Option1)	DP-SP-400-1.5
Maximum output pulse amplitude (HV), kV	3.6		2.6		1.8	1.5
Minimum working voltage (HV), kV	1.8		1.2		0.9	0.8
Maximum HV consumption (DPB load = 6 pF), W	<20	<75	<40	<90	<80	<20
Output pulse polarity	Positive					
Maximum load capacity at maximal repetition rate and HV supply, pF <sup>1</sup>	12					
HV pulse rise/fall time, ns (HV load=6pF)	<7/7		<6/6	<6.5/6.5	<6/6	<5.5/5.5
Maximum HV pulse duration at maximal repetition rate, ns	15...5000	15....1000	15....1000	15...500	15...250	15....625
Maximum HV repetition rate, kHz	50	250		500	1000	400
HV pulse delay, ns	~30					
External triggering input	1 or 2 pulses					
External triggering pulse amplitude @50Ω load, V	3.5...5					
External triggering pulse rise time, ns	<5					
External triggering pulse duration 2-input control mode, ns	>20					
External triggering pulse delay between IN1 and IN2 for 2 input control mode or IN1 pulse duration in 1- input control mode, ns <sup>2</sup>	15...5000	15....1250	15....1250	15...500	15...250	15....620
HV load capacitor protection, pF	>50					
Base plate thermal protection, °C	47...50					

<sup>1</sup> Voltage or repetition rate derating is necessary if capacitance of your Pockels cell is higher. Contact Eksma Optics for suggestions.

<sup>2</sup> Maximum pulse duration is determined by formula  $t(ns) = \frac{1000}{4 \times F(MHz)}$ , but the pulse duration must not to exceed 5000 ns.



<i>Parameter</i>	<i>Value(s)</i>					
	<i>DP-SP-50-3.6-(AI)-(Option1)</i>	<i>DP-SP-250-3.6-(AI)-(Option1)</i>	<i>DP-SP-250-2.6</i>	<i>DP-SP-500-2.6-(AI)-(Option1)</i>	<i>DP-SP-1000-1.8-(AI)-(Option1)</i>	<i>DP-SP-400-1.5</i>
Error signal optocoupler maximum current, mA	500					
Low voltage DC requirements <sup>1</sup>	+24V ±1V					
	50mA	120mA		260mA	330mA	240mA
DC Connectors		Molex Micro-Fit 3.0				
Maximal operating temperature of base plate, °C	35					
Water connector	N/A on DP-SP-50-3.6 "Festo" for OD=4mm tube on open PCB and <b>-AI-Option1</b> "Festo" on OD=6mm tube for <b>-AI</b>					
Dimensions, mm	94x63x31 on DP-SP-50-3.6 94(116)x63x38 on open PCB 99(116)x68x42 on <b>-AI-Option1</b> 114x73x50 on <b>-AI</b>					
Weight, g	255 of DP-SP-50-3.6 580 of open PCB 640 of <b>-AI-Option1</b> 980 of <b>-AI</b>					

<sup>1</sup> For driver start need 0.6A DC current.

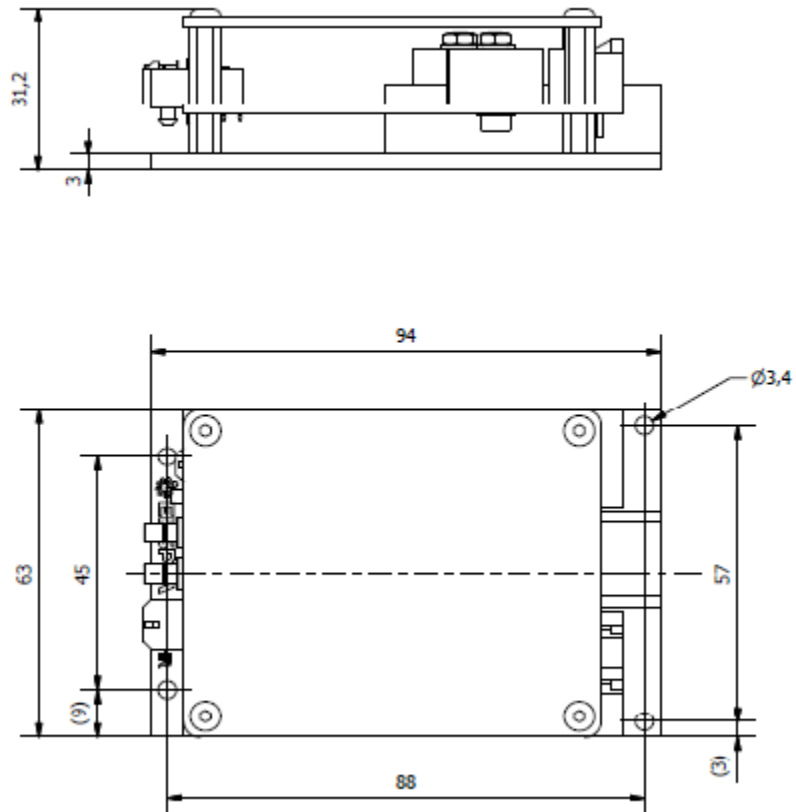

**Figure 1.** Outline drawing and dimensions of the driver **DP-SP-50-3.6**

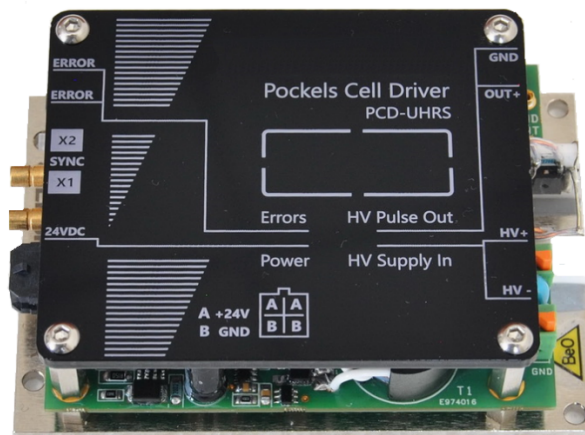

**Figure 2.** View of the driver **DP-SP-50-3.6**

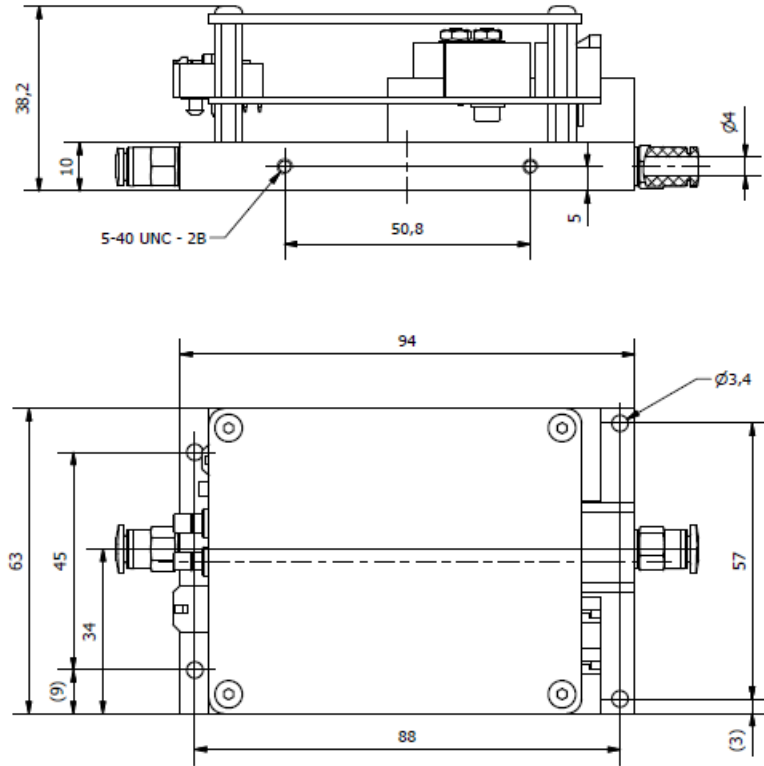

**Figure 3.** Outline drawing and dimensions of drivers **DP-SP-250-3.6**, **DP-SP-250-2.6**, **DP-SP-500-2.6**, **DP-SP-400-1.5**, **DP-SP-1000-1.8**. Open PCB version.



**Figure 4.** View of drivers **DP-SP-250-3.6**, **DP-SP-250-2.6**, **DP-SP-500-2.6**, **DP-SP-400-1.5**, **DP-SP-1000-1.8**. Open PCB version.

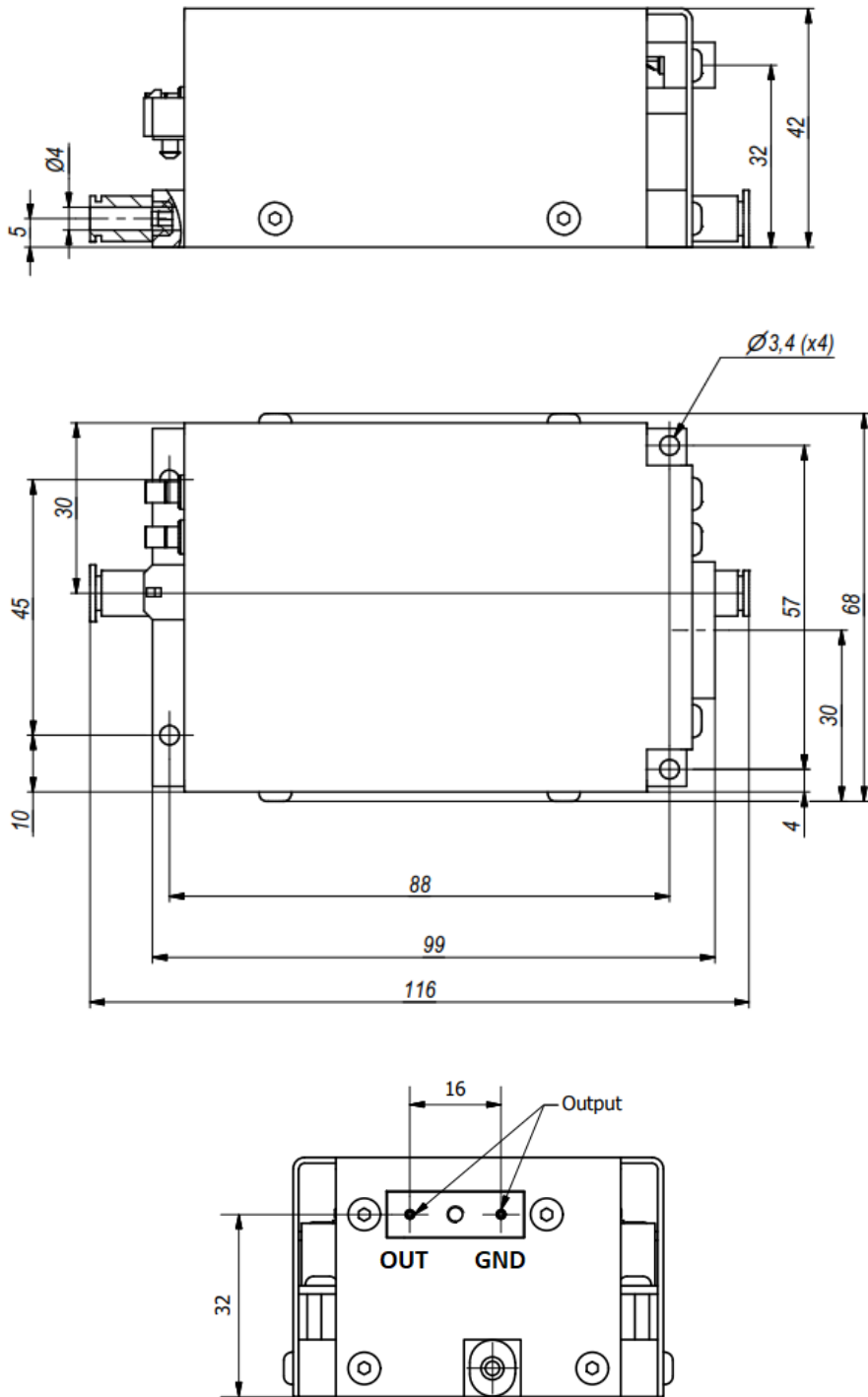

**Figure 5.** Outline drawing and dimensions of the drivers with cover (-AI-Option1)

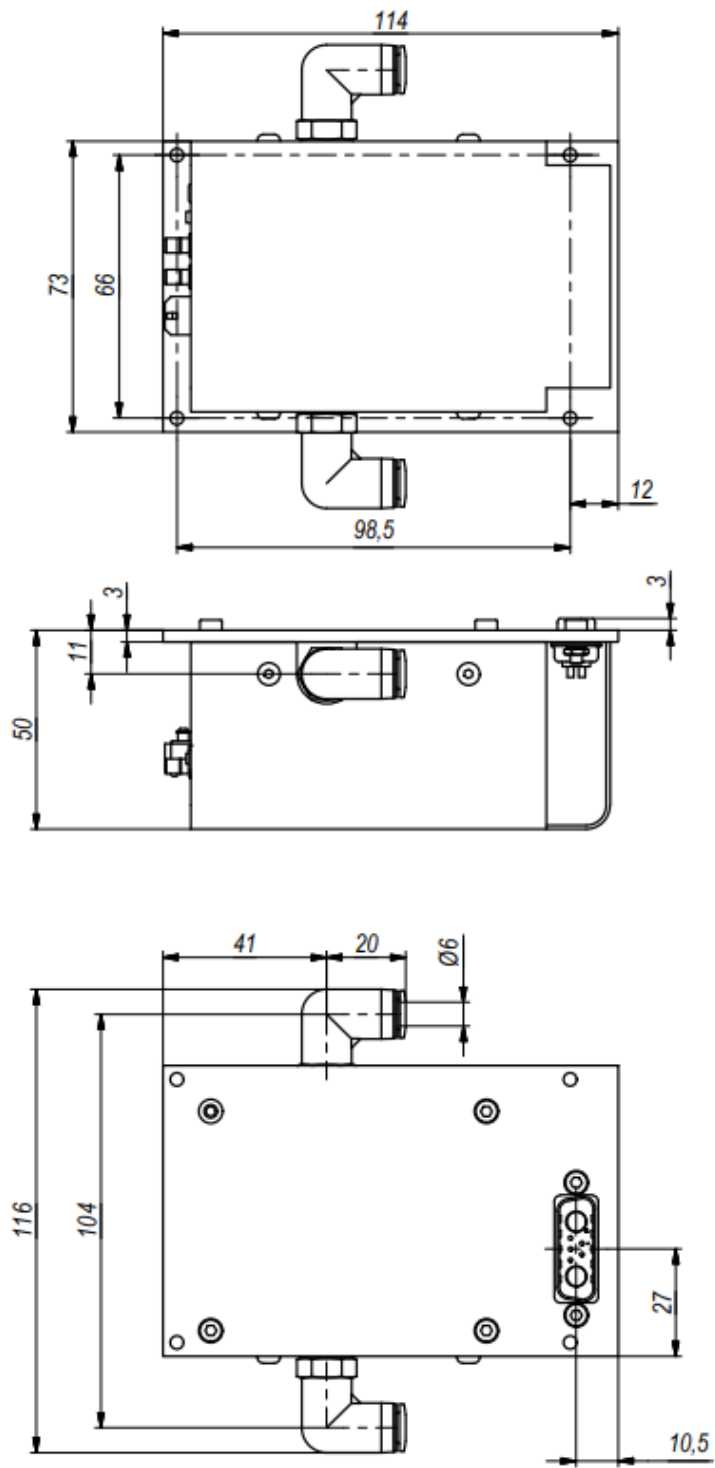

**Figure 6.** Outline drawing and dimensions of the drivers with cover (-AI)

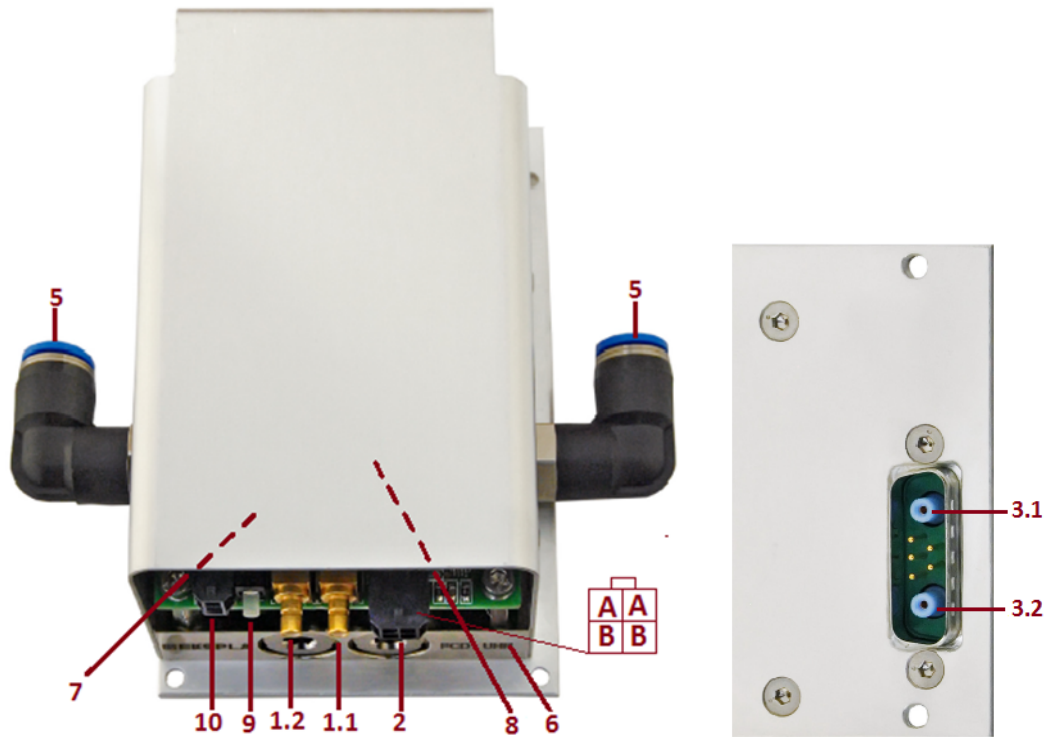

**Figure 7.** View of the driver with cover (-Al)

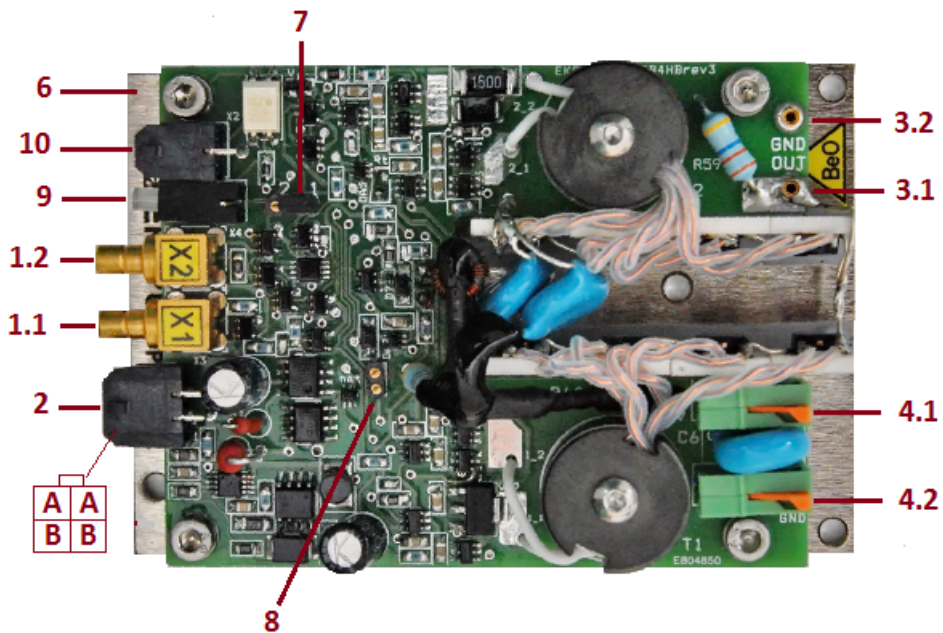

**Figure 8.** Connections and controls on the PCB of the driver

**Table 4.** Connection ports of the driver

#	<i>Port</i>
1.1	<b>X1</b> (SYNC IN1) for HV opening, or SYNC IN in 1-input control mode
1.2	<b>X2</b> (SYNC IN2) for HV closing
2	Connector Molex 4 (Microfit series) - interface for +DC (24 VDC) supply (“ <b>A</b> ” is +DC; “ <b>B</b> ” is GND)
3.1	HV pulse output pin <b>+OUT</b>
3.2	HV pulse output pin <b>GND</b>
4.1	<b>+HV</b> input from HV supply
4.2	<b>GND</b> input from HV supply
5	Water connectors
6	Cooper base plate
7	Jumper to toggle SYNC IN mode between one-and-two pulses control
8	Protection jumper
9	LED for an error display
10	Connector for an error output signal

Equipment is designed to be safe under normal environmental conditions according to 1.4.1.61010-1@IEC:2010 (Safety requirements for electrical equipment, control and laboratory use):

1. indoor use;
2. altitude up to 2000 m;
3. temperature 5°C to 35°C;
4. maximum relative humidity 80% for temperatures up to 31°C decreasing linearly to 50% relative humidity at 35°C;
5. POLLUTION degree 1: no POLLUTION or only dry, non-conductive POLLUTION occurs.

**Warning:**

***The safety of the system incorporating driver and HV power supply is the responsibility of the assembler of the system.***

Operating the driver is allowed to persons acquainted with the operation manual and having permission to deal with voltages over 1000 V.

Do not remove unit covers while power cable is connected to the mains (if applicable).

Do not touch any parts of the system when high voltage is applied, as it may cause injury or death.

Do not operate the unit until it is **grounded** and the load is connected.

Do not use the unit if any defects have been detected.



***Please read these important notes before using the product!***

1. External triggering pulses to inputs **X1** (SYNC IN1) and **X2** (SYNC IN2) may be applied only if high voltage and DC power are provided and turned on. When turning off the driver, first turn off synchronization pulses, then turn off the power. Otherwise the driver may be damaged.

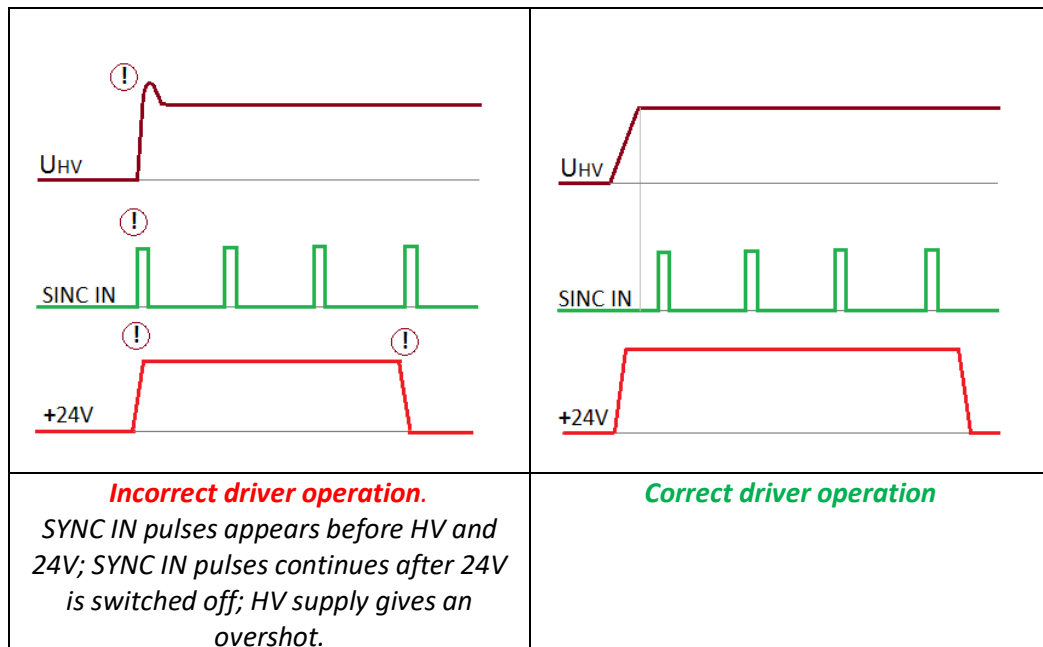

**Figure 9. Driver operation chart**

2. The output pulse is provided between **OUT** and **GND** pins. Do not connect an oscilloscope or any other device to the **OUT** pin. The wire contact with the Pockels cell must be proper in order to avoid a discharge, which may damage the driver. Do not power the driver without a capacitive load (4...10 pF) as this may damage the driver.

3. The pulse shape (including fronts) can be measured indirectly. On your oscilloscope, select 1 V sensitivity and the 1 M $\Omega$  input. Use isolated 1:10 oscilloscope probe for measurement. Move the probe *slowly* and *carefully* toward the hot output wire. When the probe is ~10 mm away from the hot output wire, the pulse shape should appear in the oscilloscope (amplitude should be several volts). Do not place the probe too close to the hot output wire – a discharge may start and damage the driver. This measurement method is not suitable for measuring >500 ns pulses.

4. Do not attempt to measure the parameters of any parts of the driver's electronics using an oscilloscope, especially when the driver is running in pulsed mode. Attempts to measure parameters of certain parts of the driver's circuitry may lead to damage.

5. **DP-SP** driver has short-circuit protection on the output. Driver stops working when load is higher than 50 pF or short circuit at the output has occurred. Red LED lights up indicating the error state. To restart the driver, +24V voltage must be turned off and turned on again.

6. **DP-SP** driver has built-in overheat protection. Driver stops working when heatsink temperature exceeds 50°C. Green LED lights up indicating the error state. Driver restarts automatically when heatsink temperature decreases below 45°C.

6. Connector #10 (Figure 8) is dry contact optocoupler error output to external equipment. Closed contact indicates normal operation, while any error as overload, short circuit at driver output or overheat turns to open contacts state. The maximum load current of the output is 500mA.

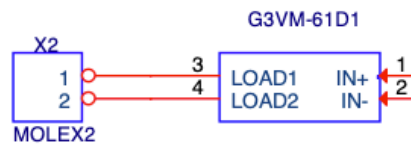

**Figure 10.** Output circuit of error connector

7. Pockels cell drivers are sensitive for rapid HV supply voltage rises. Supply voltage ramp faster than 20 V/ms can lead to driver damage. All HV power supplies from Eksma Optics has limited output voltage rise speed and can be safely used. However, using some of third party HV power supplies can be unsafe. The **DP-SP** drivers has internal protection from rapid voltage rises. The protection scheme while is switched on limits minimal driver's operating voltage at level  $0.5U_{max}$ . Using Eksma Optics HV power supplies, this protection can be safely switched off the same extending possible output tuning range. It is achieved by shortening jumper (#8 in Figure 8) with 2 mm plug.

## 6.1. Set jumper #7 to required operation mode

This step describes the commutation jumper marked “#7” in **Figure 8 / Table 4**.

The **DP-SP** driver may be controlled by one or two SYNC IN signals (see **Figure 11**), depending on the jumper position:

- Jumper position **1**: 1-input control mode  
SYNC IN1 rising edge turns HV to Pockels cell on, falling edge turns the voltage off.
- Jumper position **2**: 2-input control mode  
SYNC IN1 rising edge turns voltage on, SYNC IN2 rising edge turns the voltage off.

Either of the two jumper positions must be selected when operating the driver. Do not leave the driver with no position set on the jumper.

Cables from generator must be of equal length for control by two synchronization pulses.

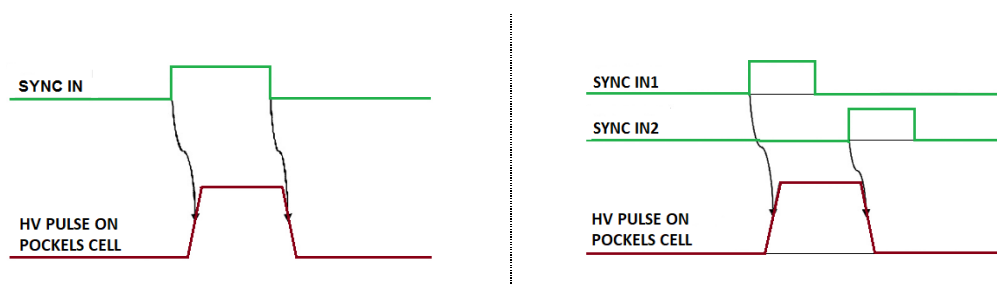

**Figure 11.** Control timing for 1-input (left) and 2-input (right) controlled driver

## 6.2. Set-up cooling

Model dependent, the driver may be cooled by water or by mounting it to a heat sink. The cooling should ensure the base plate temperature not exceeding 35°C during operation. The power to be removed by cooling is equal to HV power supply power consumption.

The water connectors installed on driver are for 4 mm OD hoses for **DP-SP-\*\*\*.\*\*\*** or **DP-SP-\*\*\*.\*\*\*-AI-(Option1)** and 6 mm OD hoses for **DP-SP-\*\*\*.\*\*\*-AI**. However, for better cooling performance, we recommend using hose extensions with bigger diameter (e.g. 6...10 mm) especially if hose connections are long.

The driver is attached to a heat sink via the copper base plate. When using an external heat sink to cool the driver, apply thermal paste or thermal conductive matt between the driver base plate and heat sink.

## 6.3. Connect wires to the Pockels cell

The wires leading from outputs **OUT1** and **OUT2** to the Pockels cell must be about 0.24 mm<sup>2</sup> CSA. Both the wires must be as short as possible and equal length. The length of each wire must be not exceeding 100 mm. They should be located at least 5 mm away from any conductive material (including the operator’s fingers and instruments) – this is done to avoid any additional capacitive load. Otherwise, driver characteristics may degrade and/or the driver may get damaged.

## 6.4. Ground the Pockels cell driver together with the generator and HV supply

---

The driver output of several kilovolts (kV) with very fast edges is a powerful source of electromagnetic interference (EMI). Please ensure proper wiring and grounding to avoid problems caused by interference.

The best solution to minimize EMI is to mount the driver and the HV power supply on the metal body of the laser. The driver base plate must have very good electrical contact with the ground wire of the HV power supply, such as the four mounting holes on the edges of the board. Ensure that these connections are firmly tighten and has god electrical connection. This is enough in most of cases.

If the EMI level is still very high, attempt mounting ferrites on all power and control wires leading to the driver and power supply (except wires to the Pockels cell).

Please note that the aluminum case of the driver is not designed to provide effective EMI shielding. Essentially, correct wiring provides best results.

## 6.5. Supply voltage to the driver from the DC power supply

---

For a safe start of the driver, the DC power supply must provide at least 0.6 A peak current when turning on. Although most DC power supplies are capable of providing this, it is recommended to double-check your supply as an insufficient peak current may damage the driver.

## 6.6. Supply voltage from the HV supply

---

Connect the HV power supply and set required voltage.

If the HV power supply is manufactured by a third party, before supplying voltage, ensure there is no overvoltage while turning it on.

## 6.7. Provide synchronization pulses from the generator

---

It is necessary to measure the generator output voltage with a 50Ω load before applying synchronization signals to the driver. The amplitude must be in range 3.5...5 V. Make sure that the duration of SYNC IN1 pulse is longer than 20 ns in single-pulse driving, or delay between SYNC IN1 and SYNC IN2 is greater than 20 ns in two-pulse driving. A shorter duration or delay of the synchronization pulses may damage the driver.

After the generator output voltage is measured, remove the 50Ω load and provide synchronization pulses to the driver.

Note that using trigger signal with longer edges and lower amplitude as specified leads to instability of output pulse amplitude, duration, delay and increased jitter. Using 5 ns or shorter trigger pulse edges are recommended. Attempt to generate shorter than 15 ns output pulses can damage the driver.

**Figure 12** presents the input circuit.

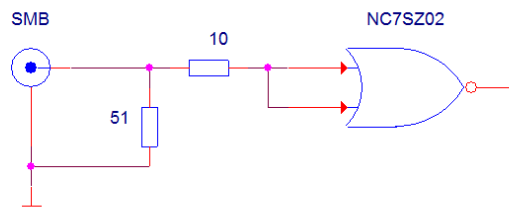

**Figure 12.** Input circuit of driver