



HIGH VOLTAGE DRIVERS

2DP-500-3.4-AI

2DP-1000-2.4-AI

2DP-2000-1.6-AI

Technical Description
Rev. 2206

2022
Lithuania

CONTENTS

CHAPTER 1	WARRANTY	1
1.1.	WARRANTY STATEMENT	1
1.2.	SERVICE CONTACT INFORMATION	1
CHAPTER 2	SPECIFICATIONS	2
2.1.	GENERAL INFORMATION	2
2.1.1.	<i>Models</i>	2
2.1.2.	<i>Main Components</i>	2
2.2.	TECHNICAL SPECIFICATIONS	3
CHAPTER 3	DEVICE LAYOUT	4
CHAPTER 4	SAFETY	6
CHAPTER 5	IMPORTANT NOTES	7
CHAPTER 6	QUICK START GUIDE	8
6.1.	SET JUMPER #4 TO REQUIRED OPERATION MODE.....	8
6.2.	SET-UP COOLING	9
6.3.	CONNECT POCKELS CELL DRIVERS OUTPUT TO POCKELS CELL	9
6.4.	GROUND THE POCKELS CELL DRIVER TOGETHER WITH THE GENERATOR AND HV SUPPLY	9
6.5.	SUPPLY VOLTAGE TO THE DRIVER FROM THE DC POWER SUPPLY	9
6.6.	SUPPLY VOLTAGE FROM THE HV SUPPLY.....	9
6.7.	PROVIDE SYNCHRONIZATION PULSES FROM THE GENERATOR.....	10
6.8.	OPERATION	11

LIST OF FIGURES

FIGURE 1. OUTLINE DRAWING AND DIMENSIONS OF THE DRIVER.....	4
FIGURE 2. TOP VIEW OF THE DRIVER.....	5
FIGURE 3. CONNECTIONS ON THE BOTTOM OF THE DRIVER.....	5
FIGURE 4. DRIVER OPERATION CHART.....	7
FIGURE 5. 2DP DRIVER.....	8
FIGURE 6. CONTROL TIMING FOR 1-INPUT (LEFT) AND 2-INPUT (RIGHT) CONTROLLED PCD1, PCD2 DRIVERS.....	8
FIGURE 7. INPUT CIRCUIT OF DRIVER.....	10
FIGURE 8. CONTROL 2DP DRIVERS WITH FREQUENCY DOUBLING.....	11
FIGURE 9. CONTROL 2DP DRIVERS WITH FREQUENCY DOUBLING AND POLARITY ALTERNATING.....	12
FIGURE 10. CONTROL 2DP DRIVERS BY TUNING OUTPUT PULSE DURATION.....	12

LIST OF TABLES

TABLE 1. MODELS.....	2
TABLE 2. MAIN COMPONENTS.....	2
TABLE 3. TECHNICAL SPECIFICATIONS.....	3
TABLE 4. PORTS SEEN IN TOP VIEW OF THE DRIVER.....	5

1.1. Warranty Statement

The Pockels cell drivers are protected by a one-year warranty covering labor and parts. The warranty enters into validity since the shipment date. Any evidence of improper use or unauthorized repair attempts voids the warranty.

1.2. Service Contact Information

For service/warranty requests, please contact:

EKSMA OPTICS, UAB
c/o EKSMA Optics, UAB
Dvarcioniu st. 2B
LT-10233 Vilnius, Lithuania

Phone: +370 5 272 99 00
Fax.: +370 5 272 92 99
E-mail: info@eksmaoptics.com
Website: www.eksmaoptics.com

2.1. General Information

2.1.1. Models

Table 1. Models

<i>Model</i>	<i>Description</i>
2DP-500-3.4-AI	2x250kHz repetition rate, 3.4kV positive output
2DP-1000-2.4-AI	2x500kHz repetition rate, 2.4kV positive output
2DP-2000-1.6-AI	2x1000kHz repetition rate, 1.6kV positive output

2.1.2. Main Components

Table 2. Main components

<i>Component</i>	<i>Quantity</i>	<i>Notes</i>
High voltage (HV) driver 2DP-**-**	1	-
DC power cable (l=1.5m)	1	-
BNC-SMB cables (l=1.5m)	2	-
HV power supply cable (l=1m)	1	-
Pair of cables for HV output to the Pockels cell (<10 cm)	1	-
Technical description	1	-

2.2. Technical Specifications

Table 3. Technical specifications

Parameter	Value(s)		
	2DP-500-3.4-AI	2DP-1000-2.4-AI	2DP-2000-1.6-AI
Maximum working (HV supply) voltage (HV), <i>kV</i>	+3.6	+2.6	+1.8
Maximum output voltage (HV), <i>kV</i>	3.4	2.4	1.6
Polarity of output pulses	Positive		
Maximum HV consumption (DPB load = 6 pF), <i>W</i>	<150	<180	<130
Maximum capacity load at maximum repetition rate and HV supply, <i>pF</i> ¹	6		
HV pulse rise/fall time, <i>ns</i> (HV load=6pF)	<7	<6.5	<6
Duration output HV pulse with doubling frequency at maximal repetition rate, <i>ns</i>	0...1900	0...900	0...400
Duration output HV pulse without doubling frequency at maximal repetition rate, <i>ns</i>	0...3800	0...1800	0...800
Maximum repetition rate using frequency doubling, <i>kHz</i>	500	1000	2000
Maximum repetition rate appearing on each of HV output, <i>kHz</i>	250	500	1000
Minimum pause between output pulses, <i>ns</i>	100		
HV pulse delay, <i>ns</i>	~30		
External triggering input	2 or 4		
External triggering pulse amplitude @50Ω load, <i>V</i>	3.5...5		
External triggering pulse rise time, <i>ns</i>	<10		
External triggering pulse duration at maximal repetition rate, <i>ns</i>	100	100...1900	100...900
Maximal triggering frequency, <i>MHz</i>	0.25	0.5	1
Low voltage DC requirements	+24V ±1V		
	0.3A	0.5A	0.65A
DC Connector	Molex Micro-Fit 3.0		
Maximal operating temperature of base plate, °C	35		
Water connector	"Festo" for OD=6mm tube		
Dimensions, <i>mm</i>	210 x 98 x 53		
Weight, <i>g</i>	2030		

¹ Voltage or repetition rate derating is necessary if capacitance of your Pockels cell is higher. Contact manufacturer for details.

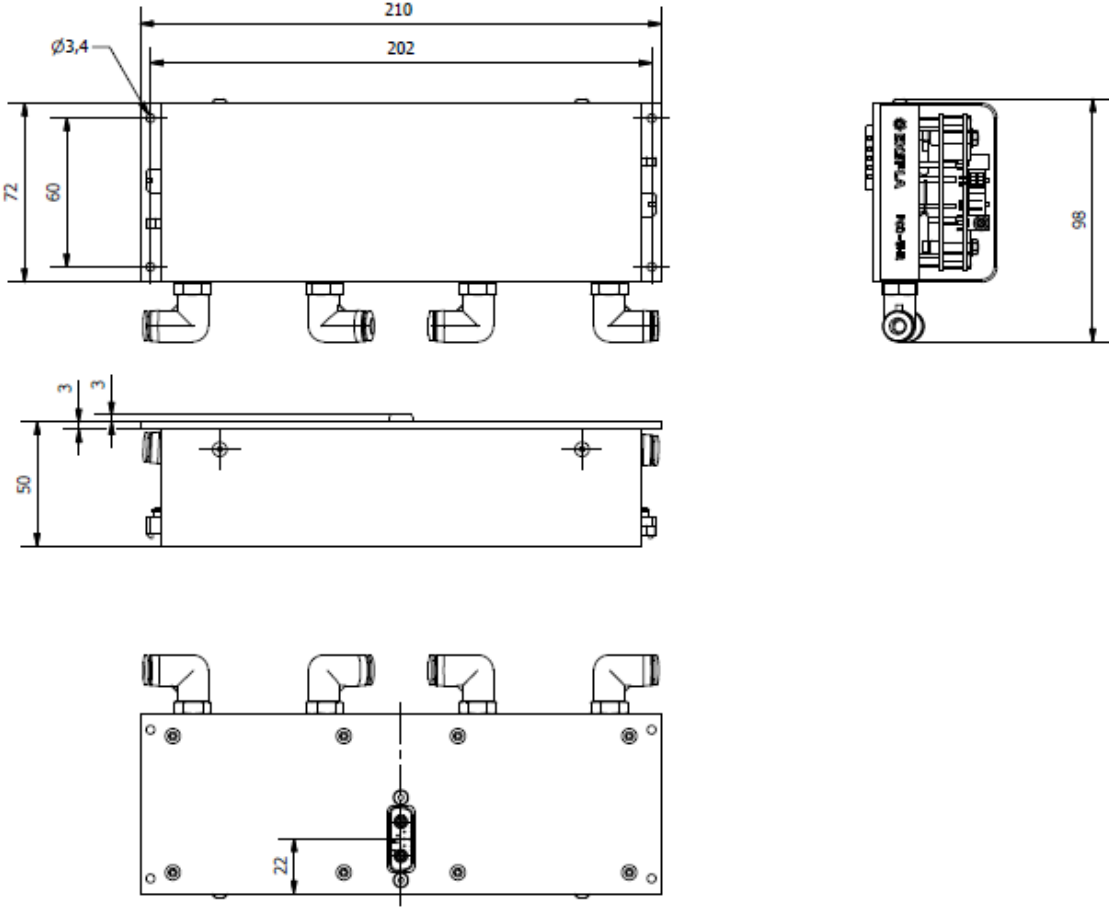

Figure 1. Outline drawing and dimensions of the driver

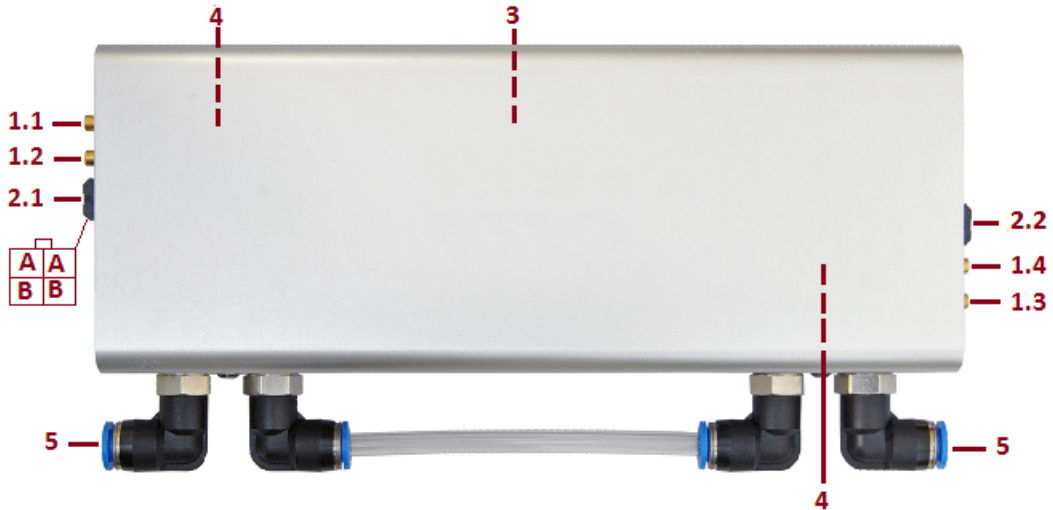

Figure 2. Top view of the driver

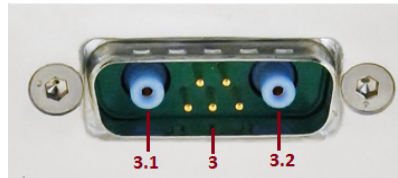

Figure 3. Connections on the bottom of the driver

Table 4. Ports seen in top view of the driver

#	Port
1.1	X1(SYNC IN1) for HV opening on PCD1, or SYNC IN1 in 1-input control mode
1.2	X2 (SYNC IN2) for HV closing on PCD1 in 2-input control mode
1.3	X3 (SYNC IN3) for HV opening on PCD2, or SYNC IN2 in 1-input control mode
1.4	X4 (SYNC IN4) for HV closing on PCD2 in 2-input control mode
2.1	Connector Molex 4 (Microfit series) - interface for +DC (24 VDC) supply ("A" is +DC; "B" is GND) for PCD1
2.2	Connector Molex 4 (Microfit series) - interface for +DC (24 VDC) supply ("A" is +DC; "B" is GND) for PCD2
3	HV pulse output connector
3.1	PCD1 HV pulse output to Pockels cell
3.2	PCD2 HV pulse output to Pockels cell
4	Jumper to toggle SYNC IN mode between one-and-two pulses control, individual for PCD1 and PCD2.
5	Connections for water cooling hoses

Equipment is designed to be safe under normal environmental conditions according to 1.4.1.61010-1@IEC:2010 (Safety requirements for electrical equipment, control and laboratory use):

1. indoor use;
2. altitude up to 2000 m;
3. temperature 5°C to 35°C;
4. maximum relative humidity 80% for temperatures up to 31°C decreasing linearly to 50% relative humidity at 35°C;
5. POLLUTION degree 1: no POLLUTION or only dry, non-conductive POLLUTION occurs.

Warning:

The safety of the system incorporating driver and HV power supply is the responsibility of the assembler of the system.

Operating the driver is allowed to persons acquainted with the operation manual and having permission to deal with voltages over 1000 V.

Do not remove unit covers while power cable is connected to the mains (if applicable).

Do not touch any parts of the system when high voltage is applied, as it may cause injury or death.

Do not operate the unit until it is **grounded** and the load is connected.

Do not use the unit if any defects have been detected.

Please read these important notes before using the product!

1. External triggering pulses to inputs **X1...X4** (SYNC IN1...SYNC IN4) may be applied only if high voltage and DC power are provided and turned on. When turning off the driver, first turn off synchronization pulses, then turn off the power. Otherwise the driver may be damaged.

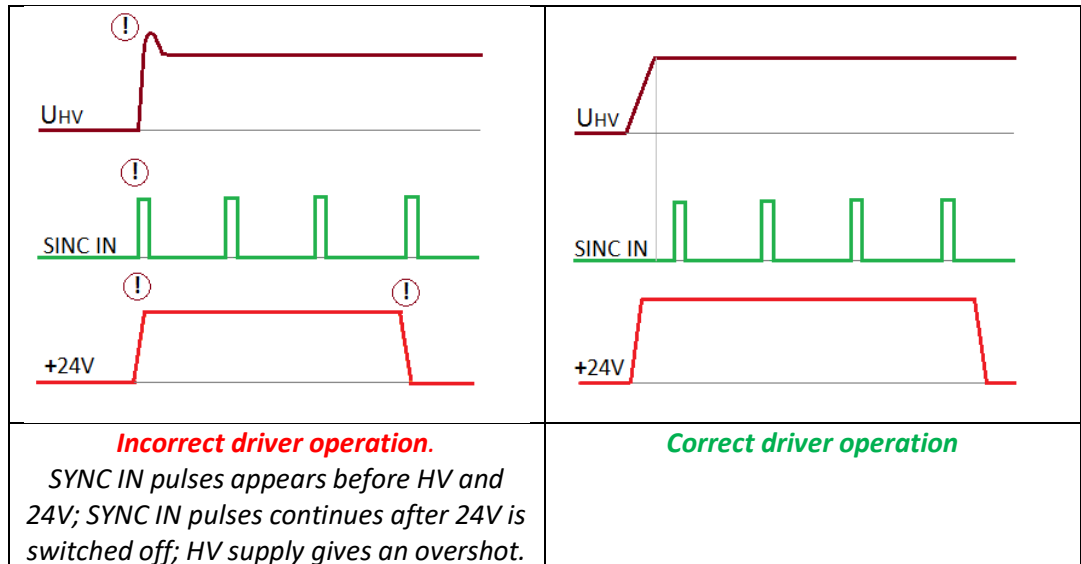

Figure 4. Driver operation chart

2. The output pulse to Pockels cell is provided between **OUT1** and **OUT2**. Both outputs are hot. Do not connect an oscilloscope or any other device to the OUT pins. The wire contact with the Pockels cell must be proper in order to avoid a discharge, which may damage the driver. Do not power the driver without a capacitive load (4...10 pF) as this may damage the driver.

3. The pulse shape (including fronts) can be measured indirectly. On your oscilloscope, select 1 V sensitivity and the 1 M Ω input. Use isolated 1:10 oscilloscope probe for measurement. Move the probe *slowly* and *carefully* toward the hot output wire. When the probe is ~10 mm away from the hot output wire, the pulse shape should appear in the oscilloscope (amplitude should be several volts). Do not place the probe too close to the hot output wire – a discharge may start and damage the driver. This measurement method is not suitable for measuring >500 ns pulses.

4. Do not attempt to measure the parameters of any parts of the driver's electronics using an oscilloscope, especially when the driver is running in pulsed mode. Attempts to measure parameters of certain parts of the driver's circuitry may lead to damage.

6.1. Set jumper #4 to required operation mode

2DP series driver consists of two individual identical drivers PCD1 and PCD2 (see **Figure 5**).

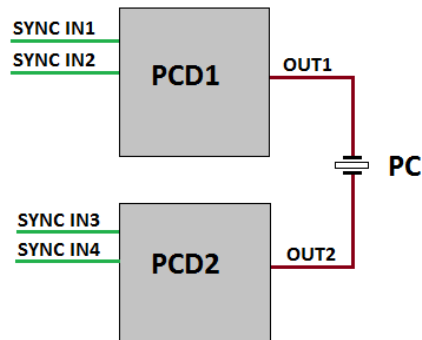

Figure 5. 2DP driver

Everyone of PCD1, PCD2 driver can be controlled by one or two SYNC IN signals (see **Figure 6**).

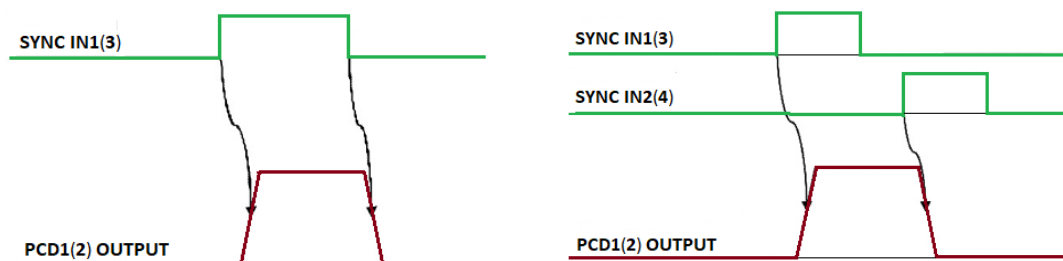

Figure 6. Control timing for 1-input (left) and 2-input (right) controlled PCD1, PCD2 drivers

This step describes the commutation jumper marked “#4” in **Figure 2/ Table 4**. The 2DP driver may be controlled by two or four SYNC IN signals, depending on the jumper position:

- Jumpers position **1**: 1-input control mode PCD1, PCD2.
SYNC IN1, SYNC IN3 rising edge turns HV to Pockels cell on, falling edge turns the voltage off.
- Jumpers position **2**: 2-input control mode PCD1, PCD2.
SYNC IN1, SYNC IN3 rising edge turns voltage on, SYNC IN2, SYNC IN4 rising edge turns the voltage off.

Either of the two jumper positions must be selected when operating the driver. Do not leave the driver with no position set on the jumper.

6.2. Set-up cooling

Model dependent, the driver may be cooled by water or by mounting it to a heat sink. The cooling should ensure the base plate temperature does not exceed 35°C during operation. The power to be removed by cooling is equal to HV power supply power consumption.

The water connectors installed on driver are for 6 mm OD hoses. However, for better cooling performance, we recommend using hose extensions with bigger diameter (e.g. 10 mm) especially if hose connections are long.

6.3. Connect Pockels cell drivers output to Pockels cell

The wires leading from outputs **OUT1** and **OUT2** to the Pockels cell must be about 0.24 mm² CSA. Both the wires must be as short as possible and equal length. The length of each wire must be not exceeding 100 mm. They should be located at least 5 mm away from any conductive material (including the operator's fingers and instruments) – this is done to avoid any additional capacitive load. Otherwise, driver characteristics may degrade and/or the driver may get damaged.

6.4. Ground the Pockels cell driver together with the generator and HV supply

The driver output of several kilovolts (kV) with very fast edges is a powerful source of electromagnetic interference (EMI). Please ensure proper wiring and grounding to avoid problems caused by interference.

The best solution to minimize EMI is mounting the driver and the HV power supply on the metal body of the laser. Use mounting holes of the driver and HV supply to ground them together with laser body. Ensure that these connections are firmly tighten and has good electrical connection. This is enough in most of cases.

If the EMI level is still very high, attempt mounting ferrites on all power and control wires leading to the driver and power supply (except wires to the Pockels cell).

Please note that the aluminum case of the driver is not designed to provide effective EMI shielding. Essentially, correct wiring provides best results.

6.5. Supply voltage to the driver from the DC power supply

For a safe start of the driver, the 24VDC power supply must provide at least 0.6 A peak current when turning on. Although most DC power supplies are capable of providing this, it is recommended to double-check your supply as an insufficient peak current may damage the driver.

6.6. Supply voltage from the HV supply

Connect the HV power supply and set required voltage.

If the HV power supply is manufactured by a third party, before supplying voltage, ensure there is no overvoltage while turning it on.

6.7. Provide synchronization pulses from the generator

It is necessary to measure the generator output voltage with a 50Ω load before applying synchronization signals to the driver. The signal voltage must be in range 3.5...5 V. Make sure that the duration of SYNC IN1(3) pulse is longer than 100 ns in single-pulse driving, or delay between SYNC IN1(3) and SYNC IN2(4) is greater than 100 ns in two-pulse driving. A shorter duration or delay of the synchronization pulses may damage the driver.

After the generator output voltage is measured, remove the 50Ω load and provide synchronization pulses to the driver.

Figure 7 presents the input circuit.

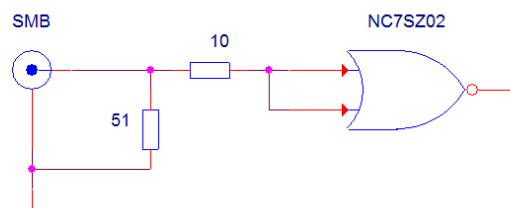

Figure 7. Input circuit of driver

6.8. Operation

1. Operation with frequency doubling. Output pulses to Pockels cell appear double frequency as any of trigger input. **Figure 8** presents the principle. SYNC1 and SYNC2 are triggering inputs. Corresponding outputs OUT1 and OUT2 of the driver repeats the time scale of SYNC inputs and presents amplitude in kV. Resulting HV pulse on Pockels cell appears as difference of these two outputs. Pulse duration to Pockels cell is tuned by shifting SYNC input's edges toward directions marked by arrows t simultaneously. The pulse duration can be tuned down to 0 unlike as in regular Pockels cell drivers. The width of pulse SYNC1 must to be about 0.5 period or longer. **Figures 8...10** timing diagrams shows control principle using 1-input triggering. The same is valid using 2-inputs control, note **Figure 6** right section.

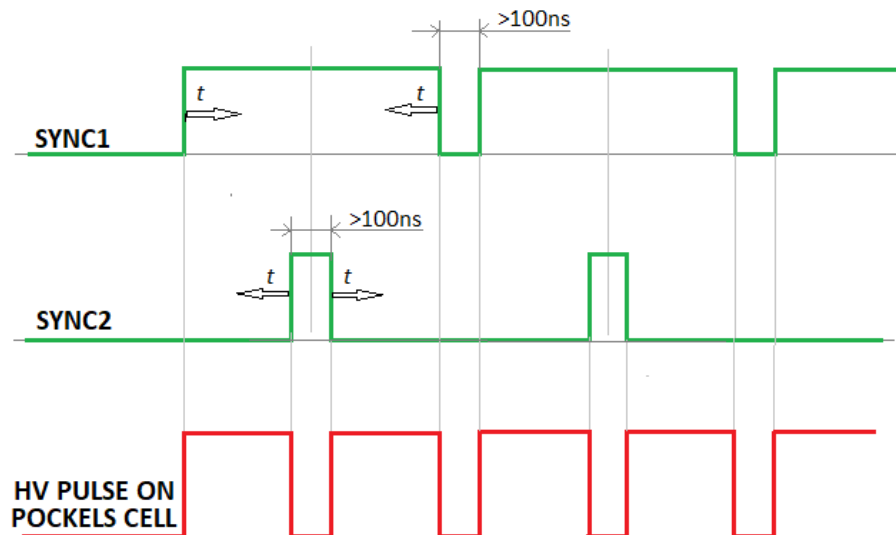

Figure 8. Control 2DP drivers with frequency doubling

2. Operation with frequency doubling and alternating voltage polarity on Pockels cell. SYNC2 pulses train is like SYNC2 but delayed in time. Output pulse duration is equal to time shift in between these two SYNC pulse trains. The pulse duration can be tuned down to 0 unlike as in regular Pockels cell drivers. Note that voltage amplitude on Pockels cell can be lower than HV supply by 20%...30% depending on Pockels cell capacitance.

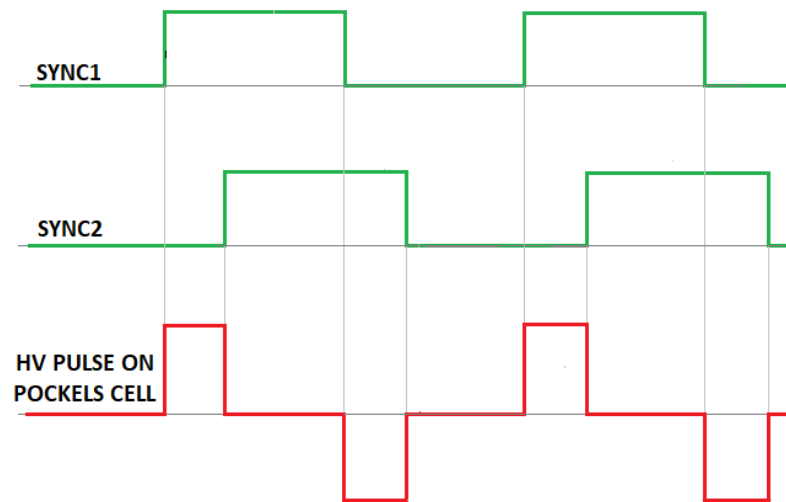

Figure 9. Control 2DP drivers with frequency doubling and polarity alternating

3. Operation with no frequency doubling and pulse duration tuning possibility from maximal down to zero. Pulse duration to Pockels cell is tuned by shifting SYNC input's edges toward directions marked by arrows.

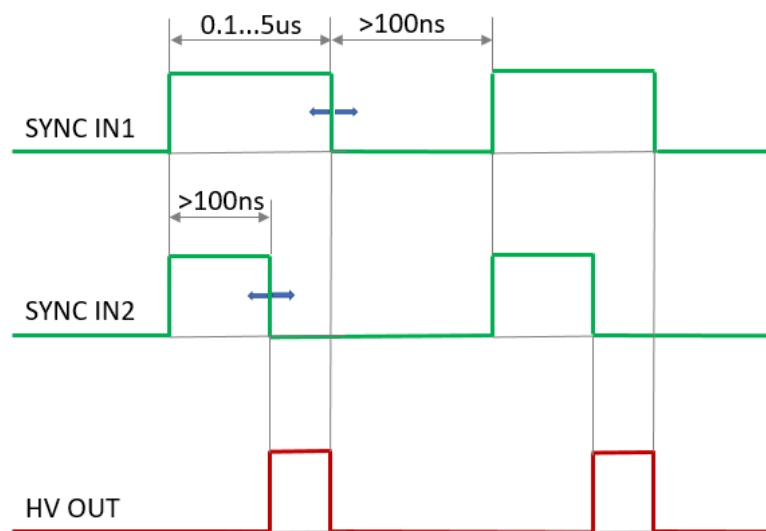

Figure 10. Control 2DP drivers by tuning output pulse duration