

1064nm Optimized Quadrant Photodetectors

Nd:YAG Optimized Silicon Photodetectors

The SPOT-YAG series are 1064 nm Nd:YAG optimized quadrant photodiodes that are well suited for aiming and pointing applications. The high performance P-type devices are manufactured with a guard ring that collects current generated outside the active to reduce noise.

They offer low capacitance and high-speed response times and are ideal for low light intensity measurements due to their low noise and high responsivity. The detectors can be operated both in photovoltaic mode (unbiased), for applications requiring low noise, or biased in the photoconductive mode, for high-speed applications.

Applications

Nd:YAG Pointing
Laser Pointing & Positioning
Position Measurement
Surface Profiling
Guidance Systems

Features

1064nm high responsivity
High Breakdown Voltage
Large Area
High Speed
High Accuracy

Absolute Maximum Ratings

Parameter	Symbol	Min	Max	Unit
Reverse Voltage	V_R	-	200	V
Operating Temperature*	T_{OP}	-10	+100	°C
Storage Temperature*	T_{STG}	-40	+125	°C

*Non-Condensing

Typical Electro-Optical Specifications at $T_A=23\text{ °C}$ §

Model	Active Area Per Element mm ²	Active Area Diameter mm	Spectral Response nm	Peak Wavelength nm	Responsivity	Element Gap mm	Dark Current		Capacitance		Rise Time	NEP	Package
					A/W		nA		pF		ns	(W/√Hz)	
					1064nm/ -180V		-180V		-180V		1060nm/ -180V/50Ω	-180V / 1064nm	
				typ	typ	typ	typ	max	typ	max	typ	typ	
SPOT-9YAG	19.6	10.0Φ	400-1100	1000	0.40	0.15	20	100	7	-	13	2.7×10^{-13}	Metal
SPOT-11AYAG-FL	26	11.5Φ	400-1100	1000	0.42	0.13	7	75	12	17	15	1.80×10^{-13}	Metal
SPOT-13AYAG-FL	33.7	13.1Φ	400-1100	1000	0.42	0.13	8	80	14	20	15	1.90×10^{-13}	Metal
SPOT-15YAG	38.5	14.0Φ	400-1100	1000	0.40	0.20	50	200	15	22	18	4.10×10^{-13}	Metal

§ All specifications are per individual elements

Spectral Response

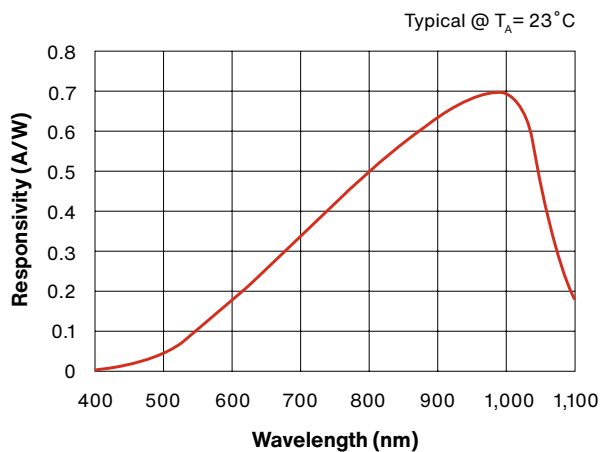

Capacitance vs. Reverse Bias

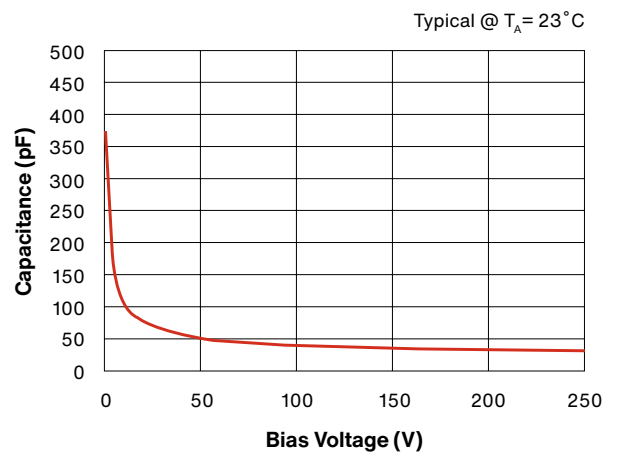

Mechanical Specifications

Units are in inches

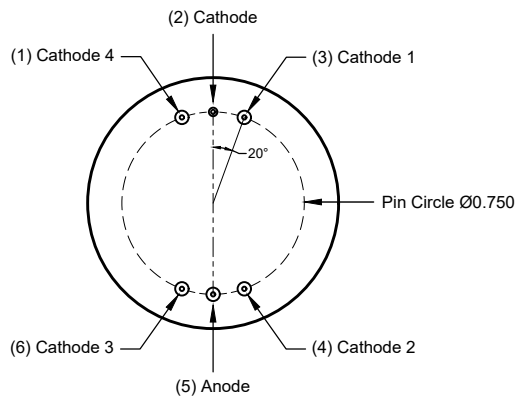
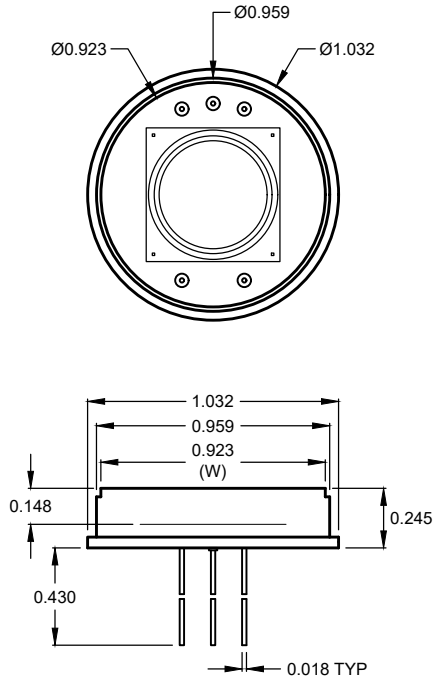

SPOT-9YAG
SPOT-15YAG

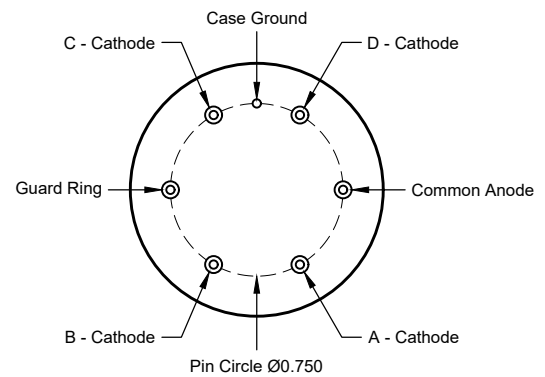
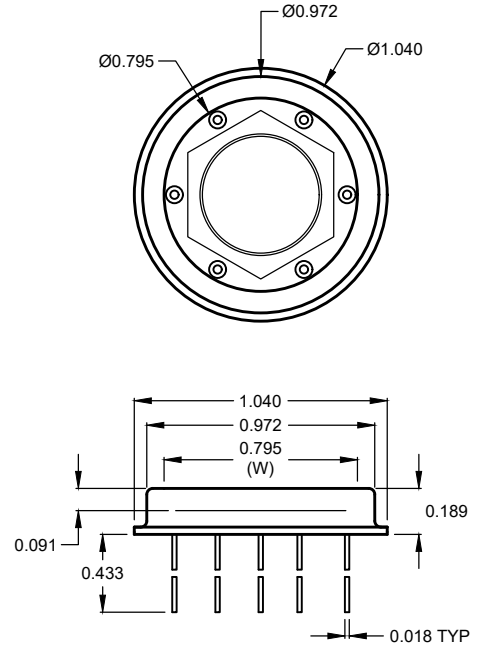

SPOT-11AYAG-FL
SPOT-13AYAG-FL

Tolerances (unless otherwise noted)

- General: 0.XX ±0.01", 0.XXX ±0.005"
- Chip Centering: ±0.010"
- Pin Diameters: 0.018 ± 0.002"

Care and handling instructions

Your photodiodes are packaged and shipped in opaque, padded containers to avoid ambient light exposure and damage due to shock from dropping or jarring.

Care must be taken to avoid photodiode exposure to high ambient light levels, particularly from tungsten sources or sunlight.

- Photodiodes can be rendered inoperable if dropped or sharply jarred. The wire bonds are delicate and can become separated from the photodiode's bonding pads when the detector is dropped or otherwise receives a sharp physical blow.
- Most windows on photodiodes are either silicon or quartz. They should be cleaned with isopropyl alcohol and a soft (optical grade) pad.
- Photodiode exposure to extreme high or low storage temperatures can affect the subsequent performance. Maintain a non-condensing environment for optimum performance and lifetime.
- All devices are considered ESD sensitive. The photodiodes are shipped in ESD protective packaging. When unpacking and using these products, anti-ESD precautions should be observed.
- Photodiode packages and/or operation may be impaired if exposed to CHLOROETHENE, THINNER, ACETONE, TRICHLOROETHYLENE or any harsh chemicals.
- Photodiodes in plastic packages should be given special care. Clear plastic packages are more sensitive to environmental stress than those of black plastic. Storing devices in high humidity can present problems when soldering. Since the rapid heating during soldering stresses the wire bonds and can cause wire to bonding pad separation, it is recommended that devices in plastic packages to be baked for 24 hours at 85°C.
- The leads on the photodiode SHOULD NOT BE FORMED. If your application requires lead spacing modification, please contact OSI Optoelectronics Applications group at (310)978-0516 before forming a product's leads. Product warranties could be voided.
- Most devices are provided with wire or pin leads for installation in circuit boards or sockets. Observe the soldering temperatures and conditions specified below:
 - Soldering Iron: Soldering 30 W or less
 - Temperature at tip of iron 300°C or lower.
 - Dip Soldering: Bath Temperature: 260±5°C.
 - Immersion Time: within 5 Sec.
 - Soldering Time: within 3 Sec.
 - Vapor Phase Soldering, Reflow Soldering: DO NOT USE

Legal Disclaimer

Information in this data sheet is believed to be correct and reliable. However, no responsibility is assumed for possible inaccuracies or omission. Specifications are subject to change without notice.



Most of our standard catalog products are RoHS Compliant. Please contact us for details.

