

VARIABLE ATTENUATOR FOR FEMTOSECOND LASER PULSES – 990-0072

FEATURES

- › Divides laser beam into two beams of manually adjustable intensity ratio separated by 68° angle
- › Large dynamic range
- › Transmitted beam shift ~1 mm
- › High optical damage threshold

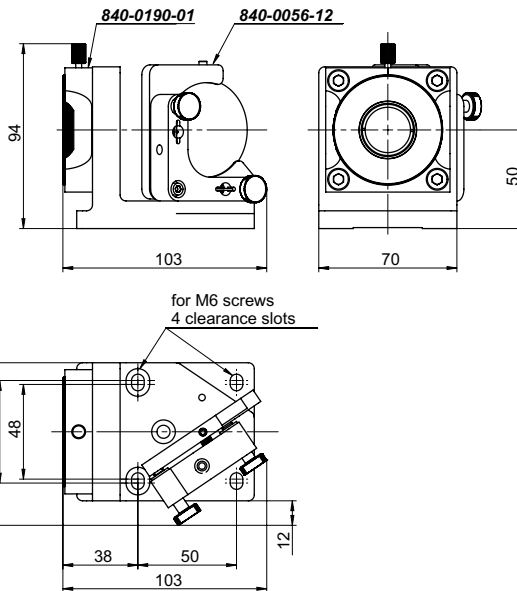

This variable attenuator/beamsplitter consists of Polarizer Holder 840-0190-01 and Kinematic Mirror/Beamsplitter Mount 840-0056-12. UVFS Thin Film Brewster type polarizer diameter 50.8 mm, which reflect s-polarized light while transmitting p-polarized light, is housed into Beamsplitter Mount 840-0056-12. A quartz Zero Order (optically contacted) Half Waveplate Ø25.4 mm (for femtosecond applications), quartz Zero Order Air-Spaced Half Waveplate (for high power femtosecond applications) or quartz Multi Order Half Waveplate Ø25.4 mm (for Nd:YAG laser applications) is housed in rotating polarizer holder 840-0180-A1 and placed in the incident linearly polarized laser beam.

The intensity ratio of those two separated and different polarized beams may be continuously varied without alteration of other beam parameters by rotating the waveplate. The intensity of either exit beam, or their intensity ratio, can be controlled over a wide dynamic range. P-polarization could be selected for maximum transmission, or high-

purity s-polarization could be reflected when maximum attenuation of the transmitted beam takes place.

The holder 840-0056-12 allows to adjust Angle Of Incidence of the Thin Film Brewster type polarizers by ±4.5° and to get the maximum extinction contrast. The mounts are on rods, rod holders and Movable Base 820-0090. The optical axis height from the table top can be adjusted in the range 78-88 mm. Other height can be offered as custom changing the standard rods and rod holders into higher.

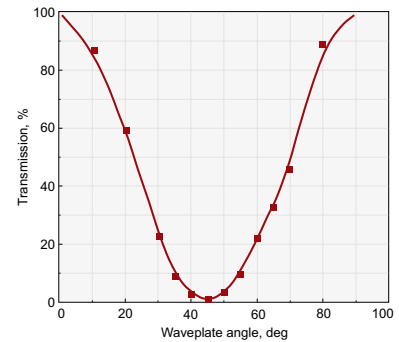

FOR Nd:YAG LASER APPLICATIONS

Clear Aperture diameter	22 mm
Damage threshold	>5 J/cm ² , 10 ns pulse, 10 Hz at 1064 nm, typical
Polarization Contrast	>1:200
Transmitted beam shift	~ 1 mm
Weight	0.45 kg

A quartz Multi Order Half Waveplate Ø25.4 mm is housed in rotating holder 840-0180-A1.

FOR Nd:YAG LASER APPLICATIONS

Wavelength, nm	Catalogue number
266	990-0072-266H *
355	990-0072-355
532	990-0072-532
1064	990-0072-1064

* A quartz Zero Order Air-Spaced Half Waveplate clear aperture Ø22 mm is housed in rotating holder 840-0190-01.

FOR HIGH POWER FEMTOSECOND LASER APPLICATIONS

Wavelength, nm	Catalogue number
266	990-0072-266H
343	990-0072-343H
400	990-0072-400H
515	990-0072-515H
800	990-0072-800H
780 – 820	990-0072-800HB
1030	990-0072-1030H
1010 – 1050	990-0072-1030HB

FOR FEMTOSECOND APPLICATIONS

Clear Aperture diameter	22 mm
Damage threshold	>10 mJ/cm ² , 50 fs pulse at 800 nm, typical
for high power applications	>100 mJ/cm ² , 50 fs pulse at 800 nm, typical
Polarization Contrast	>1:200
Transmitted beam shift	~ 1 mm
Weight	0.45 kg

A quartz Zero Order (optically contacted) Half Waveplate (for femtosecond applications) or Zero Order Air-Spaced Half Waveplate (for high power applications) Ø25.4 mm are housed in rotating holder 840-0190-01.

FOR FEMTOSECOND APPLICATIONS

Wavelength, nm	Catalogue number
266	990-0072-266
343	990-0072-343
400	990-0072-400
515	990-0072-515
800	990-0072-800
780 – 820	990-0072-800B
1030	990-0072-1030
1010 – 1050	990-0072-1030B