

Product Datasheet



PLX Electronic Autocollimator – ACT-25B

ACT-25B Electronic Autocollimator.

The ACT-25B is designed as a complete system and is practically ready to use right out of the box. It features a built-in laser for coarse alignment, a base with leveling adjustments and bubble level and focusing adjustment. When the ACT-25B is used as an autocollimator the unit has a 42-minute horizontal measurement range. In alignment telescope mode, the field of view is 84 minutes horizontally. The PLX ACT-25B autocollimator has a 0.01 arc-second resolution and a focusing range from 30cm to infinity.



PLX Autocollimator

ACT-25B Electronic Autocollimator

ACT-25FO Autofocusing Electronic Autocollimator

ACT-HR High-Resolution Electronic Autocollimator

ACT-WF Wide-Field Electronic Autocollimator

ACT-25B All-In-One Electronic Autocollimator

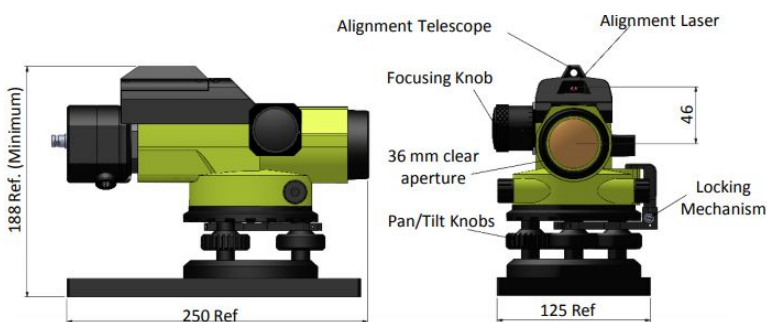

ACT-25B:

- Used to detect and measure small angular deviations.
- 0.01 arc-second resolution.
- Exceptional focusing range: 30 cm to infinity.
- Built-in laser for coarse alignment.
- Long-lasting LED light source.
- Robustly designed all-in-one unit.

Software

All PLX autocollimators come with software, and the software automatically displays angle deviation and can give the relative position of multiple targets.

Data logging is supported and can be configured to record for a predetermined time or a fixed number of data points. The recording interval can also be set. The data can be saved to a file or streamed to a remote location via RS-232 or TCP/IP. The communication setting for both RS-232 and TCP/IP is fully configurable from the software.

ACT-25B Specifications

Specification	Value
Spectral Response	350 - 1600 nm
Gain Control	1-24 dB
Shutter Speed	39 μ sec to 20 sec
FoV Autocollimator	$\pm 25'$ (V) x $\pm 40'$ (H)
FoV Telescope	$\pm 50'$ (V) x $\pm 1^{\circ} 20'$ (H)
Clear Aperture	36 mm
Resolution	0.01 sec
Accuracy	1.0 sec
Camera (Wide Spectral Range)	2.4 Mega Pixels, 12 bit
Light Source	LED- 650, optional: 1060. Special order: 1310 / 1550 nm
Line of Sight Retention as Function of Focusing	+/- 2.5 seconds
Min. Focusing Distance	Less than 30 cm
Built in coarse aiming Laser Pointer	638 nm power <1.0 mW Class 2 laser product, IEC60825-1
Synchronization	•Software •Hardware (external trigger signal)
Interface	USB 3.0
Exposure Control	Programmable via GUI
Housing Size (L x W x H) in mm	230 x 125 x 190
Power Requirements	~2.5 Watt (Via USB 3.0 interface)
Weight (typical)	2.5 kg including cable