

OSI Optoelectronics's FCI-InGaAs-36C is an OC-192 (SONET/SDH) capable photosensitive device, exhibiting low dark current and good performance stability.

Both Anode and Cathode contacts appear on the chip's top facet. And it makes ideal component in high-speed optical data transport applications at 10Gbps, responding to a spectral envelop that spans from 910nm to 1650nm.

### APPLICATIONS

- High Speed Optical Communications
- OC-192
- Optical Networking
- Optical Measurement

### FEATURES

- High Speed, 10 Gbps Data Rates
- low Dark Current
- Front Illuminated
- High Responsivity, Typ. 0.8 A/W @1550nm
- Diameter of Light Sensitive area 36 $\mu$ m
- Low Capacitance

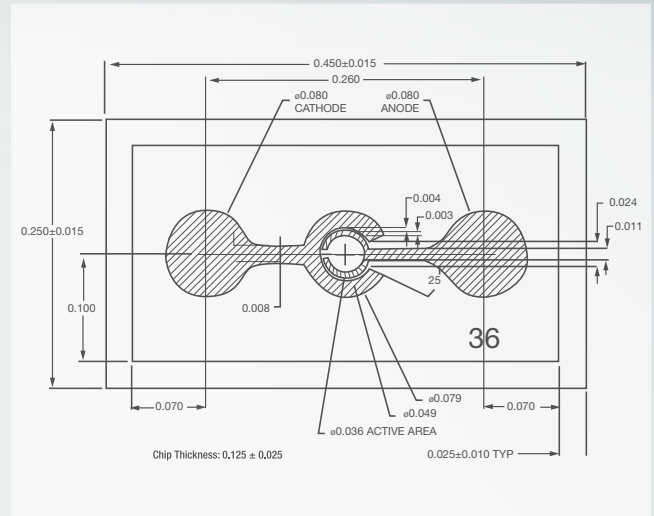

Typical Eye Diagram (10Gbps)<sup>(1)</sup>

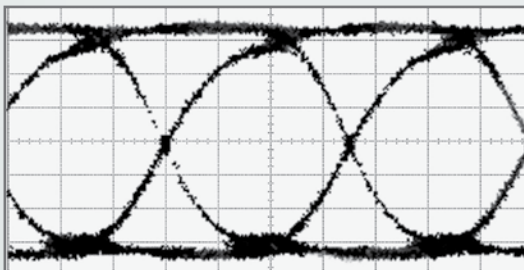

Scale: Vertical 100mV/div  
Horizontal 20.0 ps/div

Electro-Optical Characteristics						$T_A=23^\circ\text{C}$
PARAMETERS	SYMBOL	CONDITIONS	MIN	TYP	MAX	UNITS
Sensing Area Diameter	$AA_\phi$	---	---	36	---	$\mu\text{m}$
Chip Size	---	---	---	450 x 250	---	$\mu\text{m} \times \mu\text{m}$
Responsivity	$R_\lambda$	$\lambda=1310\text{nm}$	0.8	0.85	---	A/W
		$\lambda=1550\text{nm}$	0.75	0.8	---	
Capacitance	$C_j$	$V_R=5\text{V}$	---	0.16	0.2	pF
Dark Current	$I_d$	$V_R=5\text{V}$	---	0.5	2	nA
Breakdown Voltage	$V_b$	$I_R=1\mu\text{A}$	20	---	---	V
Bandwidth	---	---	---	9	---	GHz

(1) Measured with a TIA. Currently FCI-InGaAs-36C is offered in die form only.